

# **CESAB & Simai**

## **A powerful Partnership**

Tow Tractors and Platform Trucks 1.5 – 50 tonnes capacity



## 3-wheel electric tow tractor TTE15

Towing Capacity 1500 kg



3-wheel tow tractor, man on board, with front-wheel drive. Extremely fast, compact and easy to drive, perfect for indoor lightweight, short-distance, industrial towing duties.

- **Supporting chassis** ensures maximum exploitation of induction motor torque.
- Preset electrical **braking**, operating automatically when accelerator handgrip is released and on reversing direction.
- Mechanical drawbar **steering**.
- **1 operator on board**, driving while standing. Low step-on platform with suspension system for maximum driving comfort.
- **"Man on board" device** with sensor floor mat. Driver back support available upon request. Blue and flashing lights available upon request.

- **Multifunction digital dashboard** with battery charge indicator, fault detection, speedometer and hour meter
- **Induction motor based wheel-drive system.**
- **Electronic speed control of AC motor** with energy recovery during deceleration and braking. Several towing hitches available.
- **Battery** 24 V 375Ah
- Single phase **HF battery charging** on board. Standard paint finish: chassis dark grey RAL 7021/body light grey RAL 7035. Other colours available upon request.

All parts are easy to access for fast and effective maintenance. Lower costs due to AC technology and modular design.

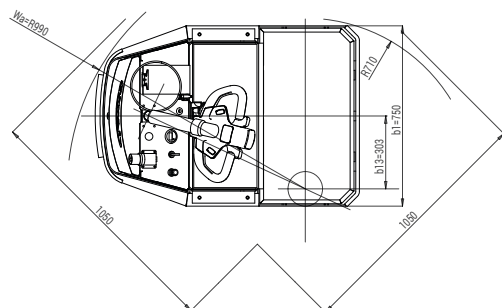
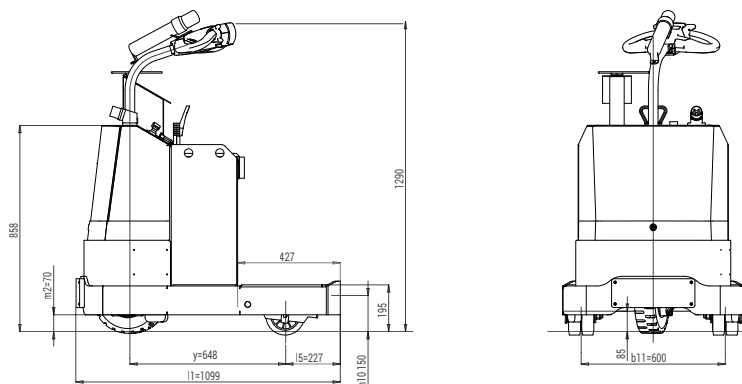

FEATURES	1.1	Manufacturer			SIMAI S.p.A.
	1.2	Model			TTE15
	1.3	Drive			electric
	1.4	Operator Type			Standing driver
	1.5	Load Capacity	Q	t	-
	1.5.1	Towing Capacity	Q	t	1,5
	1.7	Rated Drawbar pull	F	N	750
	1.9	Wheelbase	Y	mm	650
	WEIGHT	2.1	Service weight (w/battery)		Kg
2.2		Axle loading laden front/rear (with operator 80 kg. each)		Kg	292 / 314
2.3		Axle loading unladen front/rear		Kg	292 / 234
TIRES, CHASSIS	3.1	Tyres:Cushion(Cu),Superelastic(SE), Pneus(Pn) Poliurethane (PE)			SE
	3.2	Tyre size front			300x85
	3.3	Tyre size rear			160x50
	3.5	Wheels nr Front/Rear (X=motive)			1X/4
	3.6	Tread front	b <sub>10</sub>	mm	-
	3.7	Tread rear	b <sub>11</sub>	mm	600
	DIMENSIONS	4.7	Height of roof/cabin	h <sub>6</sub>	mm
4.8		Seat height	h <sub>7</sub>	mm	-
4.8.1		Step on platform height		mm	195
4.12		Coupling height	h <sub>10</sub>	mm	150
4.13		Loading height (min / MAX)	h <sub>11</sub>	mm	-
4.16		Platform length	l <sub>3</sub>	mm	-
4.17		Rear overhang	l <sub>5</sub>	mm	227
4.18		Platform width	b <sub>9</sub>	mm	-
4.19		Overall length	l <sub>1</sub>	mm	1100
4.21		Overall width	b <sub>1</sub>	mm	750
4.32		Ground clearance - centre of wheelbase	m <sub>2</sub>	mm	70
4.35		Turning radius front	Wa	mm	990
4.35.1		Turning radius rear		mm	710
4.36		Turning radius inner	b <sub>13</sub>	mm	302
4.36.1		Aisle width when turning 90°		mm	1050
PERFORMANCES	5.1	Travel speed laden/unladen		Km/h	9 / 12
	5.5	Drawbar pull laden		N	-
	5.5.1	Drawbar pull unladen		N	750
	5.6	Max. Drawbar pull laden/unladen		N	- / 1600
	5.7	Gradeability laden/unladen		%	3 / 15
	5.8	Max. Gradeability laden/unladen		%	3 / 15
	5.10	Service / Parking brake (I=Hydraulic E=Electromagn. M=Mechanical)			E / E
	5.10.1	Type of service brake front/rear			Electromagnetic/-
MOTOR	6.1	Drive motor rating S2=60 min		kW	2,3
	6.1.1	Hydrauling steering motor rating S2=60 min		kW	-
	6.3	Battery according to DIN 43531 / 35 / 36 A, B, C, no			no
	6.4	Battery voltage	U	V	24
	6.4.1	Battery rated capacity	K <sub>5</sub>	Ah	375
	6.5	Battery weight		Kg	<b>310</b>
	6.6	Energy consumption (VDI cycle)		kWh/h	-
OTHER DATA	8.1	Drive Control			Inverter AC
	8.4	Sound level at driver's ear according to DIN 12053		dB(A)	69
	8.5	Towing coupling, type DIN			-

As per VDI guidelines 2198, this datasheet applies to standard electric tractor / platform truck only. Dimensions are not binding and can be changed in any moment. The performances must be intended for brand new machines, after having completed the running-in tested in San Donato Milanese Factory in normal climatic conditions. Performances and weight are to be intended with standard motor and battery (reported in bold) and with pneumatic tires. Some data can vary according to different equipments.

## 3-wheel electric tow tractor TTE30

Towing Capacity 3000 kg



3-wheel tow tractor, man on board, with rear-wheel drive. Extremely compact and easy to drive, ideal for LEAN handling duties.

- “Shock resistant” **supporting chassis** ensures maximum exploitation of induction motor torque.
- **Drum service brake** acts on 2 rear wheels with motorbike-like lever. Electromagnetic parking brake. Preset electrical **braking**, operating automatically when accelerator handgrip is released, with first stroke of brake lever and on reversing direction.
- Fifth wheel mechanical **steering**.
- **1 operator on board.** Optimised driving position for maximum comfort and efficiency, low step-on platform for comfortable access as well as user-friendly and ergonomic dashboard. Throttle accelerator. TTE30 is designed to be driven in a seated position over long stretches and in a standing position for delivery and picking operations along production line or in warehouse.
- **“Man on board” device** with seat occupancy sensor and sensor floor mat for driving while sitting or standing.

- **Lighting system:** 1 front light, 2 rear lights (position/brake lights). Horn. Flashing light, reversing light and blue lights available upon request.
- **Multifunction digital dashboard** with battery charge indicator, fault detection and hour meter
- **Induction motor** equipped with encoder, thermal probes and negative electromagnetic parking brake with manual brake disengagement lever.
- **Electronic speed control of AC motor** with energy recovery during deceleration and braking. Several towing hitches available. Rear inching control to ease coupling operations.
- **Battery** DIN 43535B 24 V 360 Ah - fast replacement from the side or above. Standard paint finish: chassis dark grey RAL 7021/body light grey RAL 7035 or signal yellow RAL 1003. Other colours available upon request.

All parts are easy to access for fast and effective maintenance. Lower costs due to AC technology and modular design.

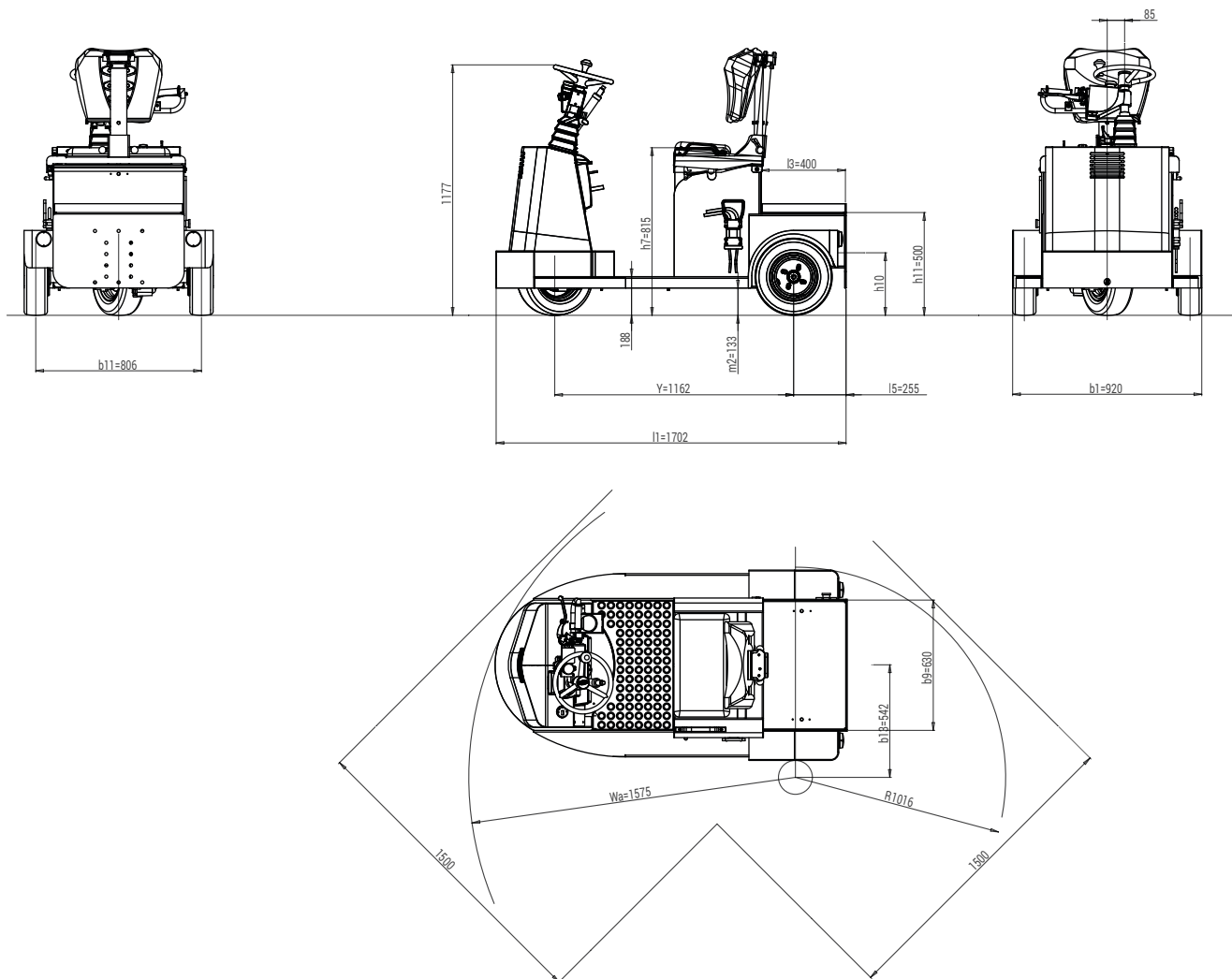

FEATURES	1.1	Manufacturer			SIMAI S.p.A.
	1.2	Model			TTE30
	1.3	Drive			Electric
	1.4	Operator Type			Sitting / standing
	1.5	Load Capacity	Q	t	0,1
	1.5.1	Towing Capacity	Q	t	3
	1.7	Rated Drawbar pull	F	N	1000
	1.9	Wheelbase	Y	mm	1162
	WEIGHT	2.1	Service weight (w/battery)		Kg
2.2		Axle loading laden front/rear (with operator 80 kg. each)		Kg	218 / 485
2.3		Axle loading unladen front/rear		Kg	178 / 345
TIRES, CHASSIS	3.1	Tyres:Cushion(Cu),Superelastic(SE), Pneus(Pn) Poliurethane (PE)			SE/Pn
	3.2	Tyre size front			15x4,5-8
	3.3	Tyre size rear			15x4,5-8
	3.5	Wheels nr Front/Rear (X=motive)			1/2X
	3.6	Tread front	b <sub>10</sub>	mm	-
	3.7	Tread rear	b <sub>11</sub>	mm	806
	DIMENSIONS	4.7	Height of roof/cabin	h <sub>6</sub>	mm
4.8		Seat height	h <sub>7</sub>	mm	815
4.8.1		Step on platform height		mm	188
4.12		Coupling height	h <sub>10</sub>	mm	215 - 270 - 325
4.13		Loading height (min / MAX)	h <sub>11</sub>	mm	500
4.16		Platform length	l <sub>3</sub>	mm	400
4.17		Rear overhang	l <sub>5</sub>	mm	255
4.18		Platform width	b <sub>9</sub>	mm	630
4.19		Overall length	l <sub>1</sub>	mm	1702
4.21		Overall width	b <sub>1</sub>	mm	920
4.32		Ground clearance - centre of wheelbase	m <sub>2</sub>	mm	133
4.35		Turning radius front	Wa	mm	1575
4.35.1		Turning radius rear		mm	1016
4.36		Turning radius inner	b <sub>13</sub>	mm	542
4.36.1		Aisle width when turning 90°		mm	1500
PERFORMANCES	5.1	Travel speed laden/unladen		Km/h	7 / 12
	5.5	Drawbar pull laden		N	-
	5.5.1	Drawbar pull unladen		N	1000
	5.6	Max. Drawbar pull laden/unladen		N	- / 3000
	5.7	Gradeability laden/unladen		%	See chart
	5.8	Max. Gradeability laden/unladen		%	See chart
	5.10	Service / Parking brake (I=Hydraulic E=Electromagn. M=Mechanical)			I / E
5.10.1	Type of service brake front/rear			- / drum	
MOTOR	6.1	Drive motor rating S2=60 min		kW	2
	6.1.1	Hydrauling steering motor rating S2=60 min		kW	-
	6.3	Battery according to DIN 43531 / 35 / 36 A, B, C, no			43535 B
	6.4	Battery voltage	U	V	24
	6.4.1	Battery rated capacity	K <sub>5</sub>	Ah	320 - <b>360</b>
	6.5	Battery weight		Kg	280 - <b>307</b>
	6.6	Energy consumption (VDI cycle)		kWh/h	-
OTHER DATA	8.1	Drive Control			Inverter AC
	8.4	Sound level at driver's ear according to DIN 12053		dB(A)	69
	8.5	Towing coupling, type DIN			-

READING EXAMPLE:  
 CHARGE = 1 TONS  
 GRADIENT = 8 %  
 DRAWBAR PULL = 1650 N  
 SPEED = 4,2 Km/h  
 MAX PRACTICABLE RAMP LENGTH = 400 m

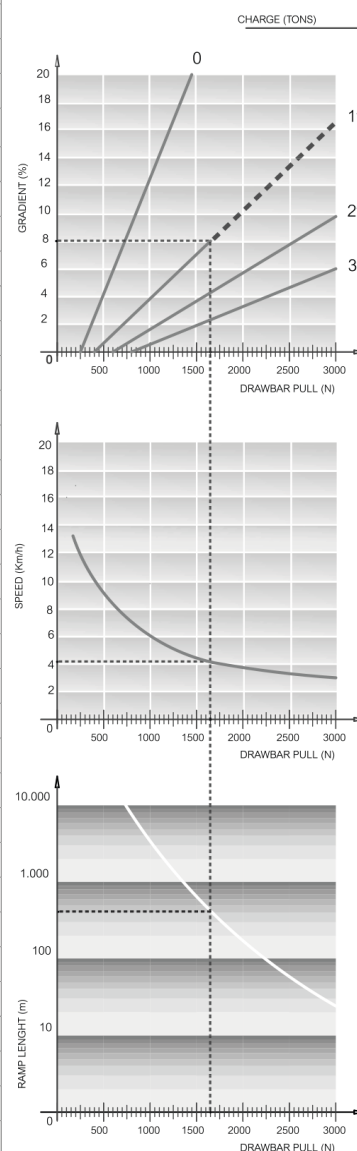

As per VDI guidelines 2198, this datasheet applies to standard electric tractor / platform truck only. Dimensions are not binding and can be changed in any moment. The performances must be intended for brand new machines, after having completed the running-in tested in San Donato Milanese Factory in normal climatic conditions. Performances and weight are to be intended with standard motors and battery (reported in bold) and with pneumatic tires. Some data can vary according to different equipments.

## 3-wheel electric tow tractor TTE40

Towing Capacity 4000 kg



3-wheel tow tractor, man on board, with rear-wheel drive. Extremely compact and easy to drive, ideal for all industrial duties - even outdoors. Height with roof is limited for towing duties in tunnels and height-restricted areas.

- “Shock resistant” **supporting chassis** ensures maximum exploitation of induction motor torque.
- **Suspensions:** front rubberised steel coil spring and shock absorber, rear steel coil springs with shock absorbers.
- **Drum service brake** acting on 3 wheels. Electromagnetic parking brake. Preset electrical **braking**, operating automatically when accelerator pedal is released, with first stroke of brake pedal and on reversing direction.
- Fifth wheel mechanical **steering**.
- **1 operator on board.** Optimised driving position for maximum comfort and efficiency, low step-on platform for comfortable access as well as user-friendly and ergonomic dashboard.
- **“Man on board” device** with seat occupancy sensor. Available in basic version, with weather protection roof with front windscreen and electric wipers. PVC canvas doors available.

- **Lighting system:** 2 front lights, 2 rear lights (position/brake lights). Horn.
- **Multifunction digital dashboard** with battery charge indicator, fault detection, speedometer and hour meter.
- **Induction motor** equipped with encoder, thermal probes and negative electromagnetic parking brake with manual brake disengage lever.
- **Electronic speed control of AC motor** with energy recovery during deceleration and braking. Several towing hitches available. Rear inching control to ease coupling operations.
- **Battery 24 V** - available capacity 240Ah, 300Ah and 360Ah. Fast replacement from the side or above. Standard paint finish: chassis dark grey RAL 7021/body light grey RAL 7035. Other colours available upon request.

All parts are easy to access for fast and effective maintenance. Lower costs due to AC technology and modular design.

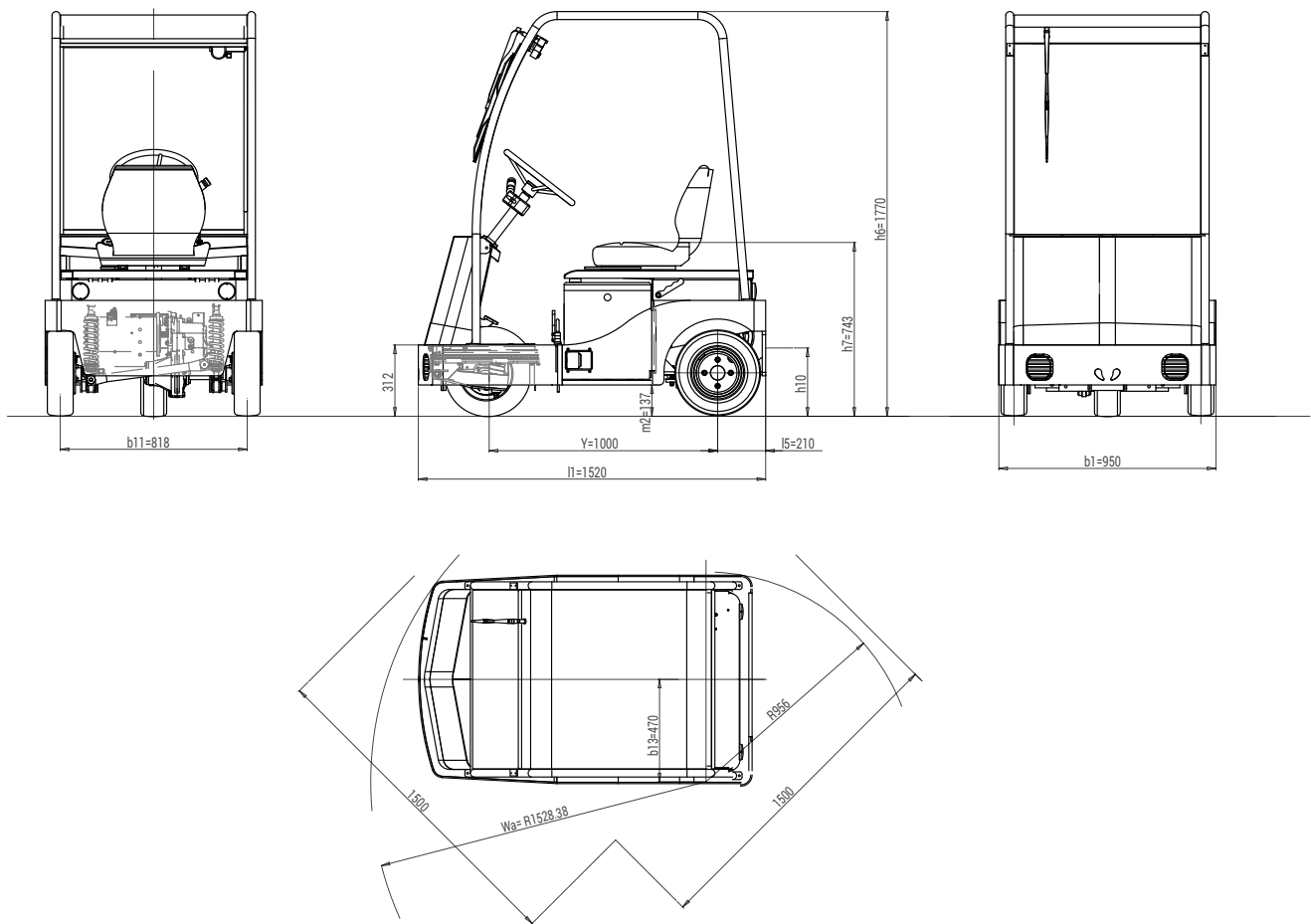

FEATURES	1.1	Manufacturer			SIMAI S.p.A.
	1.2	Model			TTE40
	1.3	Drive			Electric
	1.4	Operator Type			Sitting driver
	1.5	Load Capacity	Q	t	-
	1.5.1	Towing Capacity	Q	t	4
	1.7	Rated Drawbar pull	F	N	1000
	1.9	Wheelbase	Y	mm	1000
	WEIGHT	2.1	Service weight (w/battery)		Kg
2.2		Axle loading laden front/rear (with operator 80 kg. each)		Kg	320 / 470
2.3		Axle loading unladen front/rear		Kg	290 / 420
TIRES, CHASSIS	3.1	Tyres:Cushion(Cu),Superelastic(SE), Pneus(Pn) Poliurethane (PE)			SE/Pn
	3.2	Tyre size front			15x4,5-8
	3.3	Tyre size rear			15x4,5-8
	3.5	Wheels nr. Front/Rear (X=motive)			1/2X
	3.6	Tread front	b <sub>10</sub>	mm	-
	3.7	Tread rear	b <sub>11</sub>	mm	818
	DIMENSIONS	4.7	Height of roof/cabin	h <sub>6</sub>	mm
4.8		Seat height	h <sub>7</sub>	mm	743
4.8.1		Step on platform height		mm	312
4.12		Coupling height	h <sub>10</sub>	mm	290 - 345 - 400
4.13		Loading height (min / MAX)	h <sub>11</sub>	mm	-
4.16		Platform length	l <sub>3</sub>	mm	-
4.17		Rear overhang	l <sub>5</sub>	mm	210
4.18		Platform width	b <sub>9</sub>	mm	-
4.19		Overall length	l <sub>1</sub>	mm	1520
4.21		Overall width	b <sub>1</sub>	mm	950
4.32		Ground clearance - centre of wheelbase	m <sub>2</sub>	mm	137
4.35		Turning radius front	Wa	mm	1528
4.35.1		Turning radius rear		mm	956
4.36		Turning radius inner	b <sub>13</sub>	mm	470
4.36.1		Aisle width when turning 90°		mm	1500
PERFORMANCES	5.1	Travel speed laden/unladen		Km/h	7 / 15
	5.5	Drawbar pull laden		N	-
	5.5.1	Drawbar pull unladen		N	1000
	5.6	Max. Drawbar pull laden/unladen		N	- / 3200
	5.7	Gradeability laden/unladen		%	See chart
	5.8	Max. Gradeability laden/unladen		%	See chart
	5.10	Service / Parking brake (I=Hydraulic E=Electromagn. M=Mechanical)			I / E
5.10.1	Type of service brake front/rear			- / drum	
MOTOR	6.1	Drive motor rating S2=60 min		kW	2
	6.1.1	Hydrauling steering motor rating S2=60 min		kW	-
	6.3	Battery according to DIN 43531 / 35 / 36 A, B, C, no			no
	6.4	Battery voltage	U	V	24
	6.4.1	Battery rated capacity	K <sub>5</sub>	Ah	240 - <b>300</b> - 360
	6.5	Battery weight		Kg	300 - <b>320</b> - 340
6.6	Energy consumption (VDI cycle)		kWh/h	-	
OTHER DATA	8.1	Drive Control			Inverter AC
	8.4	Sound level at driver's ear according to DIN 12053		dB(A)	69
	8.5	Towing coupling, type DIN			-

READING EXAMPLE:  
 CHARGE = 1 TONS  
 GRADIENT = 8 %  
 DRAWBAR PULL = 1850 N  
 SPEED = 4,8 Km/h  
 MAX PRACTICABLE RAMP LENGHT = 250 m

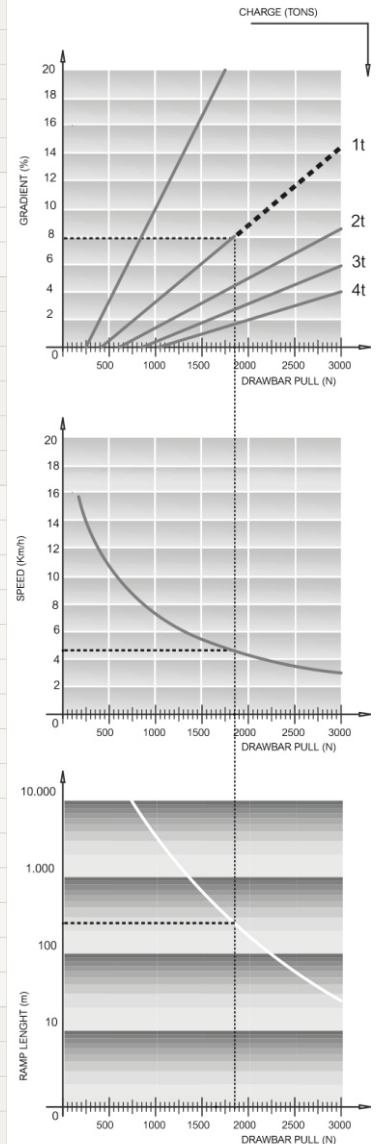

As per VDI guidelines 2198, this datasheet applies to standard electric tractor / platform truck only. Dimensions are not binding and can be changed in any moment. The performances must be intended for brand new machines, after having completed the running-in tested in San Donato Milanese Factory in normal climatic conditions. Performances and weight are to be intended with standard motors and battery (reported in bold) and with pneumatic tires. Some data can vary according to different equipments.

## 3-wheel electric tow tractor TTE71

Towing Capacity 7000 kg



3-wheel tow tractor, man on board, with rear-wheel drive. Extremely compact and easy to drive, ideal for all industrial duties - both indoors and outdoors.

- "Shock resistant" **supporting perimeter chassis** ensures maximum exploitation of induction motor torque.
- **Suspensions:** rubberised steel coil spring in the front, rubber silent block in the rear.
- **Drum service brake** acting on 3 wheels with twofold braking system. Electromagnetic parking brake. Preset electrical **braking**, operating automatically when accelerator pedal is released, with first stroke of brake pedal and on reversing direction. Fifth wheel mechanical steering.
- **1 operator on board.** Optimised driving position for maximum comfort and efficiency, low step-on platform for comfortable access as well as user-friendly and ergonomic dashboard.
- **"Man on board" device** with seat occupancy sensor. Available in basic version, with weather protection roof with front windscreen and electric wipers. PVC canvas doors or cab with hinged side doors available.

- **Lighting system:** 2 front lights (position/dipped-beam/main-beam), 2 front turn indicators, 2 rear turn indicators, 2 rear lights (position/brake lights). Horn. Flashing light, reversing light and blue lights available upon request.
- **Digital dashboard** with battery charge indicator, fault detection, speedometer and hour meter. 24 V DC/DC converter for auxiliary services.
- **Induction motor** equipped with encoder, thermal probes and negative electromagnetic parking brake with manual brake disengage lever.
- **Electronic speed control of AC motor** with energy recovery during deceleration and braking. Several towing hitches available. Rear inching control to ease coupling operations.
- **Battery** DIN 43531A 48 V - available capacity 315Ah, 345Ah and 375Ah. Standard paint finish: chassis dark grey RAL 7021/body light grey RAL 7035. Other colours available upon request.

All parts are easy to access for fast and effective maintenance. Lower costs due to AC technology and modular design.

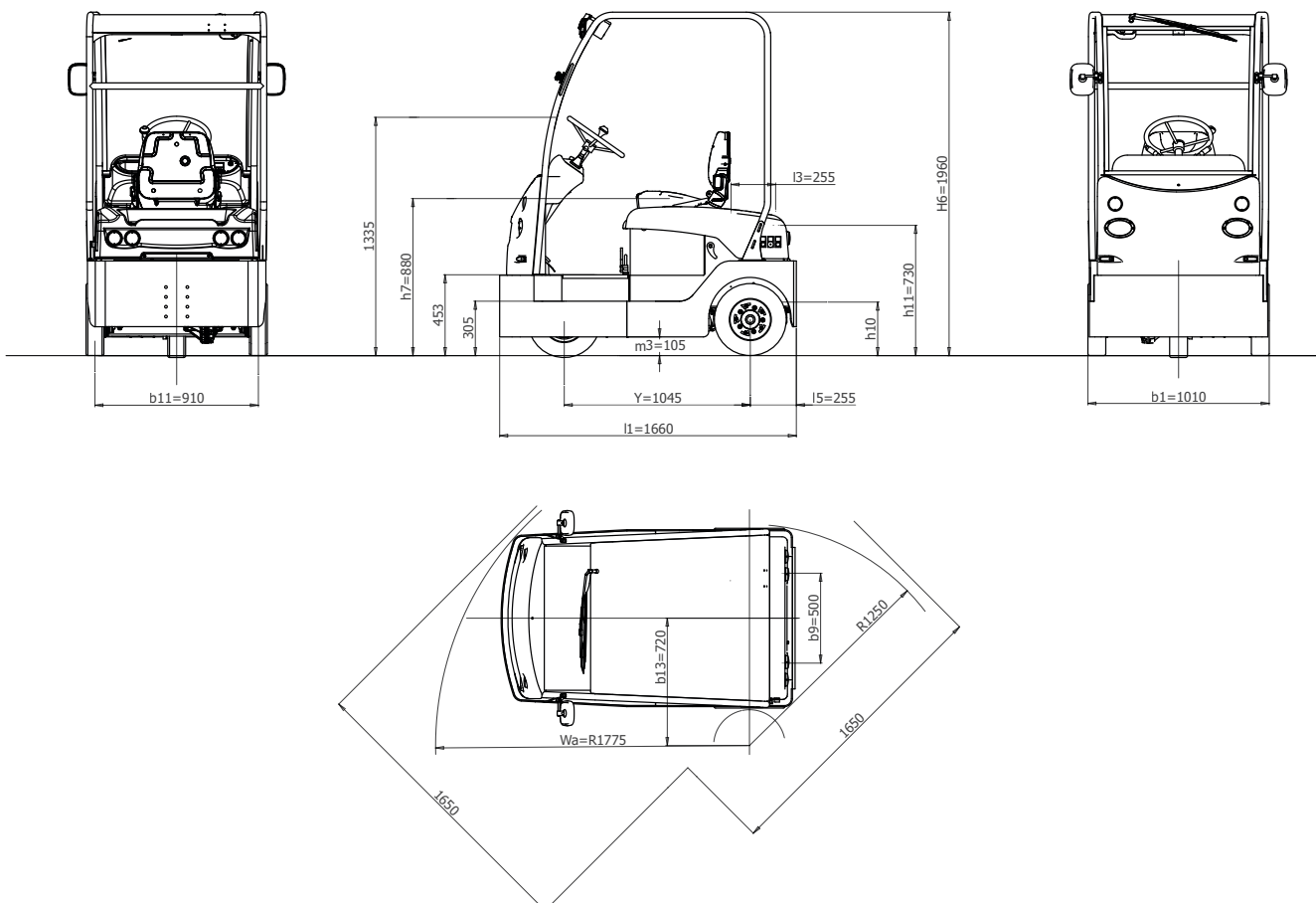



FEATURES	1.1	Manufacturer			SIMAI S.p.A.
	1.2	Model			TTE71
	1.3	Drive			electric
	1.4	Operator Type			Sitting driver
	1.5	Load Capacity	Q	t	
	1.5.1	Towing Capacity	Q	t	7
	1.7	Rated Drawbar pull	F	N	1550
	1.9	Wheelbase	Y	mm	1045
	WEIGHT	2.1	Service weight (w/battery)		Kg
2.2		Axle loading laden front/rear (with operator 80 kg. each)		Kg	-
2.3		Axle loading unladen front/rear		Kg	465 / 600
TIRES, CHASSIS	3.1	Tyres:Cushion(Cu),Superelastic(SE), Pneus(Pn) Poliurethane (PE)			SE/PN
	3.2	Tyre size front			4.00-8
	3.3	Tyre size rear			4.00-8
	3.5	Wheels nr Front/Rear (X=motive)			1/2X
	3.6	Tread front	$b_{10}$	mm	-
	3.7	Tread rear	$b_{11}$	mm	910
	DIMENSIONS	4.7	Height of roof/cabin	$h_6$	mm
4.8		Seat height	$h_7$	mm	880
4.8.1		Step on platform height		mm	
4.12		Coupling height	$h_{10}$	mm	245 - 300 - 355
4.13		Loading height (min / MAX)	$h_{11}$	mm	730
4.16		Platform length	$l_3$	mm	255
4.17		Rear overhang	$l_5$	mm	
4.18		Platform width	$b_9$	mm	650
4.19		Overall length	$l_1$	mm	1660
4.21		Overall width	$b_1$	mm	1010
4.32		Ground clearance - centre of wheelbase	$m_2$	mm	105
4.35		Turning radius front	$Wa$	mm	1775
4.35.1		Turning radius rear		mm	1250
4.36		Turning radius inner	$b_{13}$	mm	205
4.36.1		Aisle width when turning 90°		mm	1650
PERFORMANCES	5.1	Travel speed laden/unladen		Km/h	8,5 / 18
	5.5	Drawbar pull laden		N	-
	5.5.1	Drawbar pull unladen		N	1550
	5.6	Max. Drawbar pull laden/unladen		N	6000
	5.7	Gradeability laden/unladen		%	
	5.8	Max. Gradeability laden/unladen		%	4 / 22
	5.10	Service / Parking brake (I=Hydraulic E=Electromagn. M=Mechanical)			I / E
5.10.1	Type of service brake front/rear			Drum / Drum	
MOTOR	6.1	Drive motor rating S2=60 min		kW	5
	6.1.1	Hydrauling steering motor rating S2=60 min		kW	-
	6.3	Battery according to DIN 43531 / 35 / 36 A, B, C, no			43531 A
	6.4	Battery voltage	U	V	48
	6.4.1	Battery rated capacity	$K_5$	Ah	315 - 345 - 375
	6.5	Battery weight		Kg	536 - 550 - 580
	6.6	Energy consumption (VDI cycle)		kWh/h	-
OTHER DATA	8.1	Drive Control			inverter AC
	8.4	Sound level at driver's ear according to DIN 12053		dB(A)	69
	8.5	Towing coupling, type DIN			-

READING EXAMPLE:  
 CHARGE = 1 TONS  
 GRADIENT = 13 %  
 DRAWBAR PULL = 3300 N  
 SPEED = 6,2 Km/h  
 MAX PRACTICABLE RAMP LENGHT = 1500 m

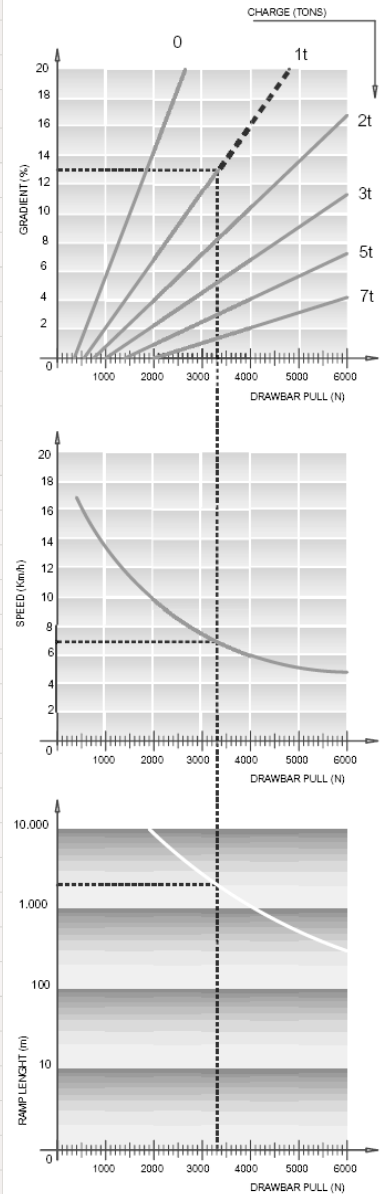

As per VDI guidelines 2198, this datasheet applies to standard electric tractor / platform truck only. Dimensions are not binding and can be changed in any moment. The performances must be intended for brand new machines, after having completed the running-in tested in San Donato Milanese Factory in normal climatic conditions. Performances and weight are to be intended with standard motors and battery (reported in bold) and with pneumatic tires. Some data can vary according to different equipments.

## 3-wheel electric tow tractor TTE100

Towing Capacity 10000 kg



3-wheel tow tractor, with on-board operator and rear-wheel drive. Extremely easy to drive, ideal for all heavy duties - both indoors and outdoors. "AGV ready".

- "Shock resistant" **supporting perimeter chassis** ensures maximum exploitation of AC motor torque.
- **Suspensions:** rubberised steel coil spring in the front, steel coil springs with shock absorbers in the rear.
- **Drum service brake** acting on 3 wheels with twofold braking system. Electromagnetic parking brake. Preset electrical braking, operating automatically when accelerator pedal is released, with first stroke of brake pedal and when reversing direction.
- Fifth wheel "**steer-by-wire**" electric steering.
- **1 operator on board.** Optimised driving position for maximum comfort and efficiency, low step-on platform for comfortable access as well as user-friendly and ergonomic dashboard.
- "**Man on board**" device with seat occupancy sensor.
- **Lighting system:** 2 front lights (position/dipped-beam/main-beam), 2 front turn indicators, 2 rear turn indicators, 2 rear lights (position/brake lights). Horn.
- **Digital dashboard** with battery charge indicator, fault detection, speedometer and hour meter.
- 24 V DC/DC converter for auxiliary services.

- **2 AC motors** equipped with encoder, thermal probes and negative electromagnetic parking brake. Electronic differential for optimal torque management also in turning manoeuvres.
- **Electronic AC control** with energy recovery and braking during deceleration.
- Several towing hitches available. Rear inching control to ease coupling operations.
- DIN 43531A 48 V battery – available capacity 420Ah, 460Ah and 500Ah.

#### Available options:

Pneumatic, superelastic or non-marking **tyres**. **Standard version without roof and cab**, available with **weather protection roof** with front windscreen, electric wiper, front and rear lights (position/brake/reversing lights/turn indicators), 2 small exterior rearview mirrors - full-LED lights; available also with canvas doors or with **full cab with hinged side doors**.

Electric **heating**.

**Flashing light** and blue safety light.

Standard paint finish: chassis dark grey RAL 7021/body light grey RAL 7035. Other colours available upon request.

All parts are easy to access for fast and effective maintenance. Lower costs due to AC technology and modular design.

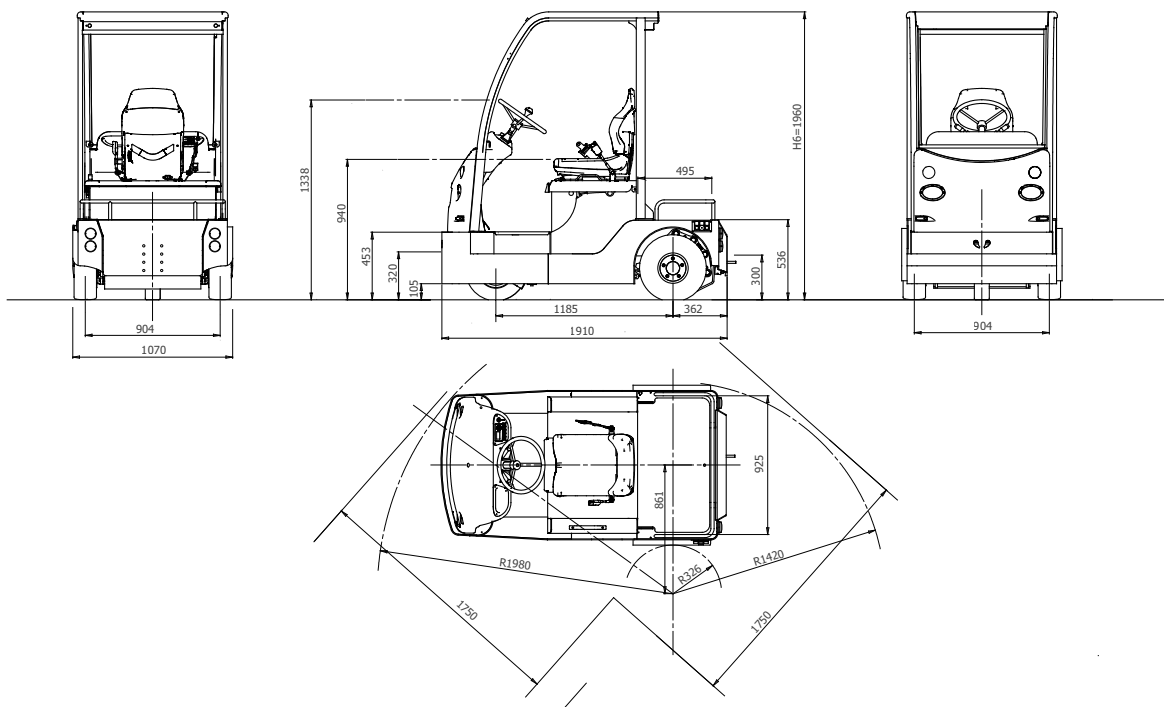

FEATURES	1.1	Manufacturer			SIMAI S.p.A.
	1.2	Model			TTE100
	1.3	Drive			Electric
	1.4	Operator Type			Seated
	1.5	Load Capacity	Q	t	0,1
	1.5.1	Towing Capacity	Q	t	10
	1.7	Rated Drawbar pull	F	N	2200
	1.9	Wheelbase	Y	mm	1264
WEIGHTS	2.1	Service weight (w/battery)		Kg	1370
	2.2	Axle loading laden front/rear (with operator 80 kg. each)		Kg	-
	2.3	Axle loading unladen front/rear		Kg	585 / 785
TYRES - CHASSIS	3.1	Tyres:Cushion(Cu),Superelastic(SE), Pneus(Pn) Poliurethane (PE)			SE/PN
	3.2	Tyre size front			4.00-8
	3.3	Tyre size rear			18x7-8
	3.5	Wheels nr Front/Rear (X=motive)			1/2X
	3.6	Tread front	$b_{10}$	mm	-
	3.7	Tread rear	$b_{11}$	mm	934
	DIMENSIONS	4.7	Height of roof/cabin	$h_6$	mm
4.8		Seat height	$h_7$	mm	880
4.8.1		Step on platform height		mm	453
4.12		Coupling height	$h_{10}$	mm	245 - 300 - 355
4.13		Loading height (min / MAX)	$h_{11}$	mm	580
4.16		Platform length	$l_3$	mm	650
4.17		Rear overhang	$l_5$	mm	371
4.18		Platform width	$b_9$	mm	900
4.19		Overall length	$l_1$	mm	1996
4.21		Overall width	$b_1$	mm	1090
4.32		Ground clearance - centre of wheelbase	$m_2$	mm	105
4.35		Turning radius front	Wa	mm	2077
4.35.1		Turning radius rear		mm	1495
4.36		Turning radius inner	$b_{13}$	mm	919
4.36.1		Aisle width when turning 90°		mm	1800
PERFORMANCES	5.1	Travel speed laden/unladen		Km/h	8,5 / 18
	5.5	Drawbar pull laden		N	-
	5.5.1	Drawbar pull unladen		N	2200
	5.6	Max. Drawbar pull laden/unladen		N	8000
	5.7	Gradeability laden/unladen		%	4/35%
	5.8	Max. Gradeability laden/unladen		%	
	5.10	Service / Parking brake (I=Hydraulic E=Electromagn. M=Mechanical)			I / E
	5.10.1	Type of service brake front/rear			Drum/drum
MOTOR	6.1	Drive motor rating S2=60 min		kW	2 x 6,6
	6.1.1	Hydraulic steering motor rating S2=60 min		kW	-
	6.3	Battery according to DIN 43531 / 35 / 36 A, B, C, no			43531 A
	6.4	Battery voltage	U	V	48
	6.4.1	Battery rated capacity	$K_5$	Ah	420-460-500
	6.5	Battery weight		Kg	667-700-731
	6.6	Energy consumption (VDI cycle)		kW	-
OTHER DATA	8.1	Drive Control			inverter AC
	Varie	Sound level at driver's ear according to DIN 12053		dB(A)	69
	8.5	Towing coupling, type DIN			-

As per VDI guidelines 2198, this datasheet applies to standard electric tractor / platform truck only. Dimensions are not binding and can be changed in any moment. The performances must be intended for brand new machines, after having completed the running-in tested in San Donato Milanese Factory in normal climatic conditions. Performances and weight are to be intended with standard motors and battery (reported in bold) and with extra-elastic tires. Some data can vary according to different equipments.

## 4-wheel electric tow tractor TE80

Towing Capacity 8000 kg



4-wheel tow tractor, man on board, with rear-wheel drive. Extremely compact and easy to drive, ideal for all industrial duties - both indoors and outdoors, even on long distances. Loading capacity of rear platform 100 kg.

- “Shock resistant” **supporting perimeter chassis** ensures maximum exploitation of induction motor torque.
- **Complete automotive lighting** and signal system. Led lights.
- **Suspensions: rubberised steel coil springs in the front, steel coil springs with shock absorbers in the rear**
- **Drum service brake** acting on 4 wheels with twofold braking system. Electromagnetic parking brake. Preset electrical **braking**, operating automatically when accelerator pedal is released, with first stroke of brake pedal and on reversing direction.
- **Mechanical steering. Hydraulic steering available upon request.**
- **1 operator on board.** Optimised driving position for maximum comfort and efficiency as well as user-friendly and ergonomic dashboard. Passenger seat available upon request.
- **“Man on board” device** with seat occupancy sensor Available in basic version, with weather protection roof with front windscreen and electric wipers. PVC canvas doors or cab with hinged side doors available.
- **Lighting system:** 2 front lights (dipped-beam/main-beam), 2 front turn indicators, 2 rear turn indicators, 2 rear lights (position/brake lights). Full LED technology Horn. Flashing light, reversing light and blue lights available upon request
- **Digital dashboard** with battery charge indicator, fault detection, speedometer and hour meter. 24 V DC/DC converter for auxiliary services.
- **Induction motor** equipped with encoder, thermal probes and negative electromagnetic parking brake with manual brake disengage lever.
- **Electronic speed control of AC motor** with energy recovery during deceleration and braking. Several towing hitches available. Rear inching control to ease coupling operations.
- **Battery** DIN 43531A 48 V - available capacity 315Ah, 345Ah and 375Ah. Standard paint finish: chassis dark grey RAL 7021/body light grey RAL 7035. Other colours available upon request.

All parts are easy to access for fast and effective maintenance. Lower costs due to AC technology and modular design.

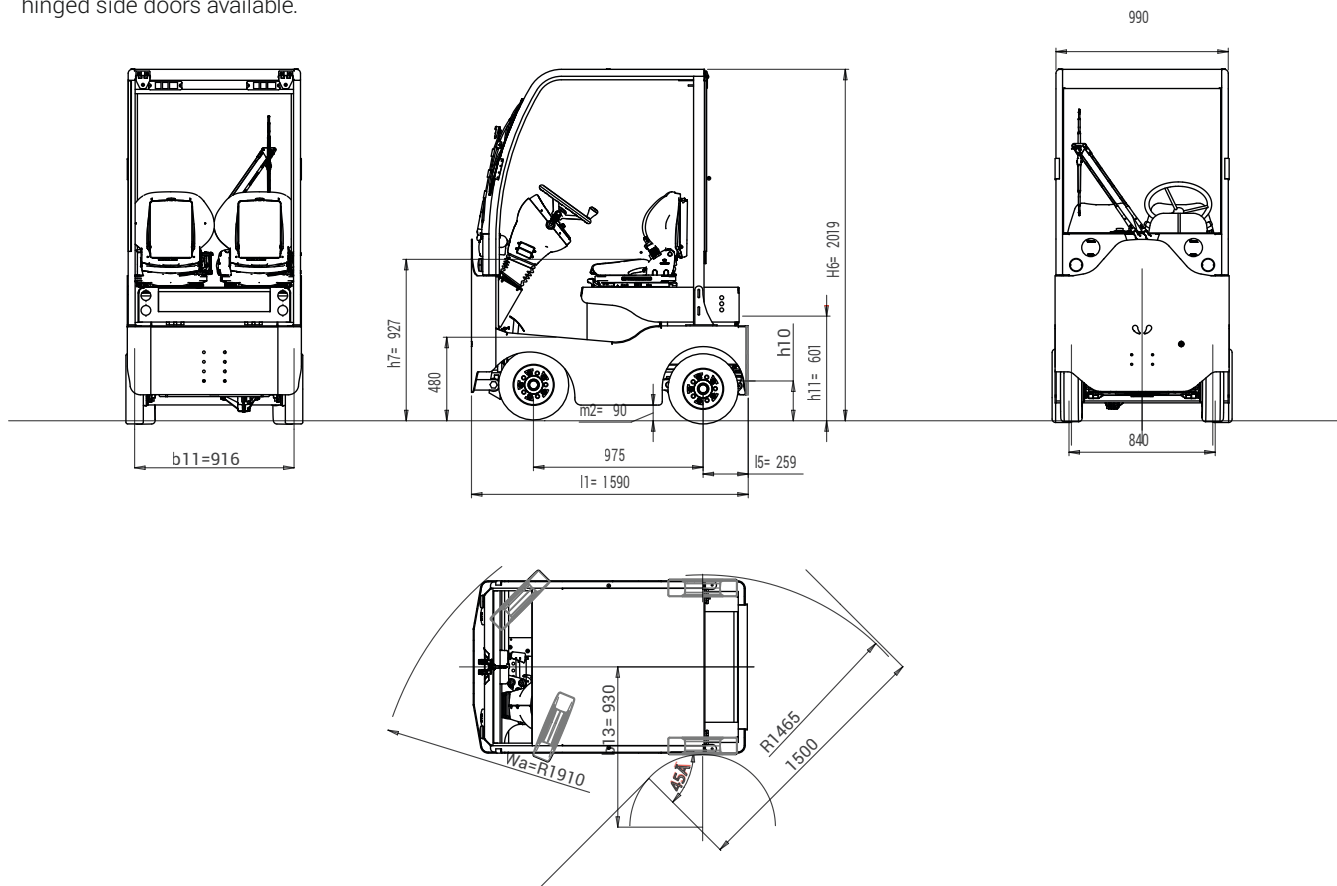

FEATURES	1.1	Manufacturer			SIMAI S.p.A.
	1.2	Model			TE80
	1.3	Drive			Electric
	1.4	Operator Type			Sitting driver
	1.5	Load Capacity	Q	t	0,1
	1.5.1	Towing Capacity	Q	t	8
	1.7	Rated Drawbar pull	F	N	1900
	1.9	Wheelbase	Y	mm	975
	WEIGHT	2.1	Service weight (w/battery)		Kg
2.2		Axle loading laden front/rear (with operator 80 kg. each)		Kg	614 / 795
2.3		Axle loading unladen front/rear		Kg	585 / 645
TIRES, CHASSIS	3.1	Tyres:Cushion(Cu),Superelastic(SE), Pneus(Pn) Poliurethane (PE)			SE/Pn
	3.2	Tyre size front			4.00-8
	3.3	Tyre size rear			4.00-8
	3.5	Wheels nr. Front/Rear (X=motive)			2/2X
	3.6	Tread front	b <sub>10</sub>	mm	810
	3.7	Tread rear	b <sub>11</sub>	mm	912
	DIMENSIONS	4.7	Height of roof/cabin	h <sub>6</sub>	mm
4.8		Seat height	h <sub>7</sub>	mm	1010
4.8.1		Step on platform height		mm	500
4.12		Coupling height	h <sub>10</sub>	mm	265 - 320 - 375
4.13		Loading height (min / MAX)	h <sub>11</sub>	mm	600
4.16		Platform length	l <sub>3</sub>	mm	350
4.17		Rear overhang	l <sub>5</sub>	mm	258
4.18		Platform width	b <sub>9</sub>	mm	650
4.19		Overall length	l <sub>1</sub>	mm	1595
4.21		Overall width	b <sub>1</sub>	mm	1000
4.32		Ground clearance - centre of wheelbase	m <sub>2</sub>	mm	105
4.35		Turning radius front	Wa	mm	1910
4.35.1		Turning radius rear		mm	1465
4.36		Turning radius inner	b <sub>13</sub>	mm	930
4.36.1		Aisle width when turning 90°		mm	1500
PERFORMANCES		5.1	Travel speed laden/unladen		Km/h
	5.5	Drawbar pull laden		N	-
	5.5.1	Drawbar pull unladen		N	1900
	5.6	Max. Drawbar pull laden/unladen		N	- / 6200
	5.7	Gradeability laden/unladen		%	See chart
	5.8	Max. Gradeability laden/unladen		%	See chart
	5.10	Service / Parking brake (I=Hydraulic E=Electromagn. M=Mechanical)			I / E
	5.10.1	Type of service brake front/rear			Drum / drum
MOTOR	6.1	Drive motor rating S2=60 min		kW	5
	6.1.1	Hydrauling steering motor rating S2=60 min		kW	0,55
	6.3	Battery according to DIN 43531 / 35 / 36 A, B, C, no			43531 A
	6.4	Battery voltage	U	V	48
	6.4.1	Battery rated capacity	K <sub>5</sub>	Ah	315 - 345 - <b>375</b>
	6.5	Battery weighth		Kg	536 - 550 - <b>580</b>
	6.6	Energy consumption (VDI cycle)		kWh/h	-
OTHER DATA	8.1	Drive Control			Inverter AC
	8.4	Sound level at driver's ear according to DIN 12053		dB(A)	69
	8.5	Towing coupling, type DIN			-

READING EXAMPLE:  
 CHARGE = 1 TONS  
 GRADIENT = 13 %  
 DRAWBAR PULL = 3330 N  
 SPEED = 7 Km/h  
 MAX PRACTICABLE RAMP LENGTH = 2000 m

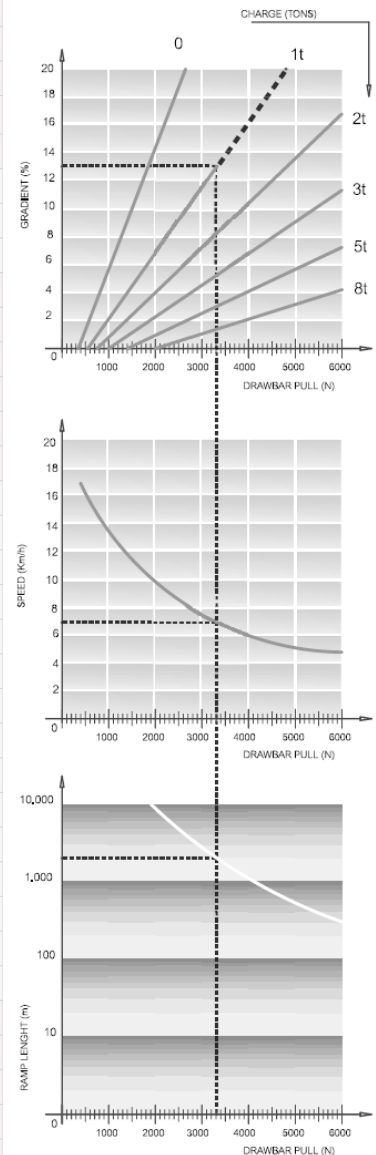

As per VDI guidelines 2198, this datasheet applies to standard electric tractor / platform truck only. Dimensions are not binding and can be changed in any moment. The performances must be intended for brand new machines, after having completed the running-in tested in San Donato Milanese Factory in normal climatic conditions. Performances and weight are to be intended with standard motors and battery (reported in bold) and with pneumatic tires. Some data can vary according to different equipments.

**CESAB** Simai

# 4-wheel electric tow tractor TE801XB

Towing Capacity 8000 kg



4-wheel tow tractor, man on board, with rear-wheel drive. Extremely easy to drive, ideal for all duties - both indoors and outdoors. Ideal solution whenever the operator has to get off frequently for hooking and unhooking operations. Loading capacity of rear platform 100 kg.

- “Shock resistant” **supporting perimeter chassis** ensures maximum exploitation of induction motor torque.
- **Suspensions:** rubberised steel coil springs in the front, steel coil springs with shock absorbers in the rear
- **Drum service brake** acting on 4 wheels with twofold braking system. Electromagnetic parking brake. Preset electrical **braking**, operating automatically when accelerator pedal is released, with first stroke of brake pedal and on reversing direction.
- Standard hydraulic **steering**.
- **1 operator on board.** Optimised driving position for maximum comfort and efficiency, low step-on platform for comfortable access as well as user-friendly and ergonomic dashboard. Passenger seat available upon request.
- **“Man on board” device** with seat occupancy sensor Available in basic version, with weather protection roof with front windscreen and electric wipers. PVC canvas doors or cab with hinged or sliding side doors available. Height with weather protection roof/cab max. 1790 mm.

- **Lighting system:** 2 front lights (dipped-beam/main-beam), 2 front turn indicators, 2 rear turn indicators, 2 rear lights (position/brake lights). Full LED technology Horn. Flashing light, reversing light and blue lights available upon request
- **Digital dashboard** with battery charge indicator, fault detection, speedometer and hour meter 24 V DC/DC converter for auxiliary services.
- **Induction motor** equipped with encoder, thermal probes and negative electromagnetic parking brake with manual brake disengage lever.
- **Electronic speed control of AC motor** with energy recovery during deceleration and braking. Several towing hitches available. Rear inching control to ease coupling operations.
- **Battery** DIN 43531A 48 V – available capacity 315Ah, 345Ah and 375Ah. Battery fitted behind driving position for fast replacement from above. Standard paint finish: chassis dark grey RAL 7021/body light grey RAL 7035. Other colours available upon request.

All parts are easy to access for fast and effective maintenance. Lower costs due to AC technology and modular design.

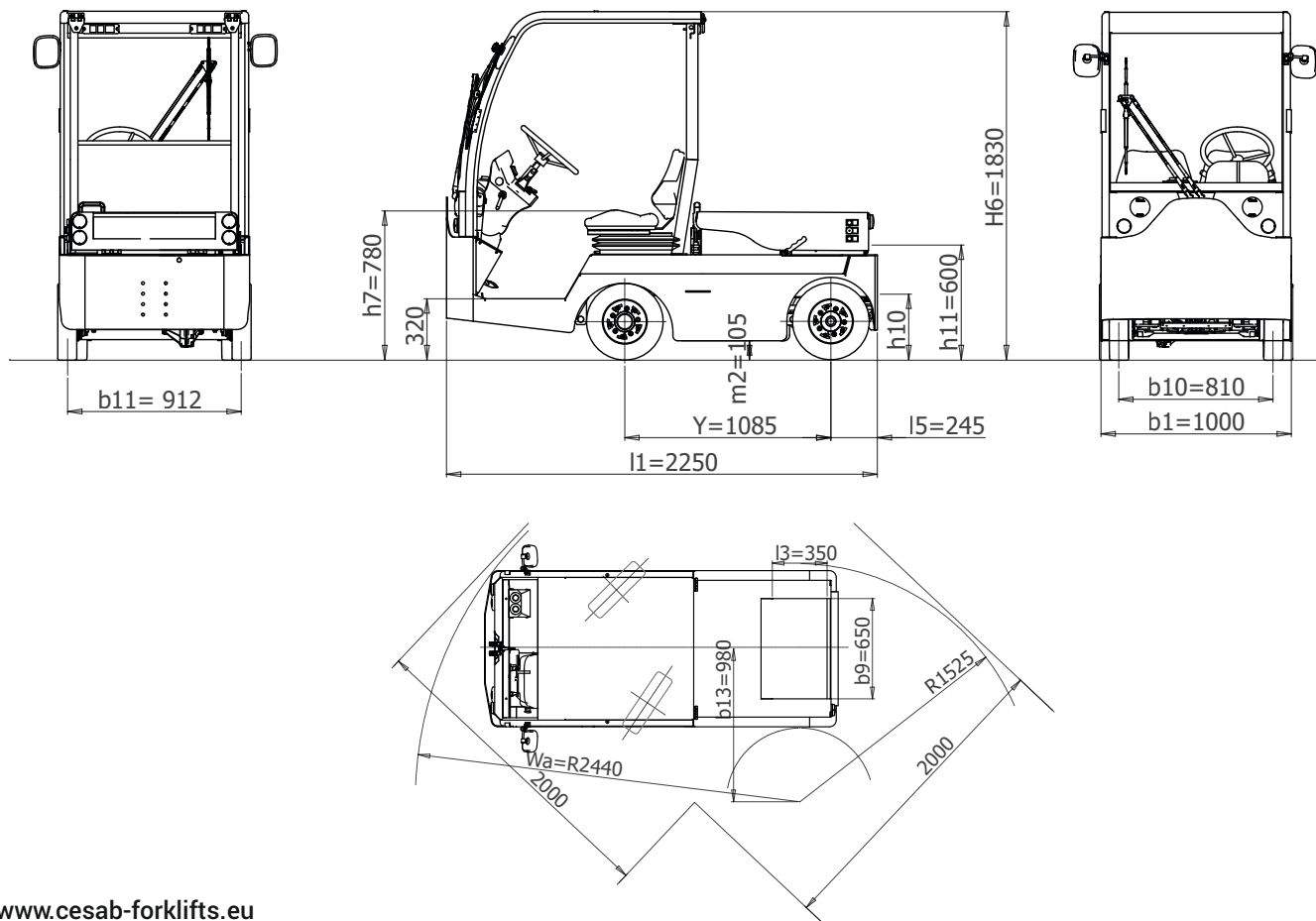

FEATURES	1.1	Manufacturer			SIMAI S.p.A.
	1.2	Model			TE801XB
	1.3	Drive			Electric
	1.4	Operator Type			Sitting driver
	1.5	Load Capacity	Q	t	0,1
	1.5.1	Towing Capacity	Q	t	8
	1.7	Rated Drawbar pull	F	N	1900
	1.9	Wheelbase	Y	mm	1070
	WEIGHT	2.1	Service weight (w/battery)		Kg
2.2		Axle loading laden front/rear (with operator 80 kg. each)		Kg	745 / 690
2.3		Axle loading unladen front/rear		Kg	650 / 605
TIRES, CHASSIS	3.1	Tyres:Cushion(Cu),Superelastic(SE), Pneus(Pn) Poliurethane (PE)			SE/Pn
	3.2	Tyre size front			4.00-8
	3.3	Tyre size rear			4.00-8
	3.5	Wheels nr Front/Rear (X=motive)			2/2X
	3.6	Tread front	b <sub>10</sub>	mm	810
	3.7	Tread rear	b <sub>11</sub>	mm	912
	DIMENSIONS	4.7	Height of roof/cabin	h <sub>6</sub>	mm
4.8		Seat height	h <sub>7</sub>	mm	780
4.8.1		Step on platform height		mm	320
4.12		Coupling height	h <sub>10</sub>	mm	265 - 320 - 375
4.13		Loading height (min / MAX)	h <sub>11</sub>	mm	600
4.16		Platform length	l <sub>3</sub>	mm	350
4.17		Rear overhang	l <sub>5</sub>	mm	255
4.18		Platform width	b <sub>9</sub>	mm	650
4.19		Overall length	l <sub>1</sub>	mm	2250
4.21		Overall width	b <sub>1</sub>	mm	1000
4.32		Ground clearance - centre of wheelbase	m <sub>2</sub>	mm	105
4.35		Turning radius front	Wa	mm	2440
4.35.1		Turning radius rear		mm	1525
4.36		Turning radius inner	b <sub>13</sub>	mm	980
4.36.1		Aisle width when turning 90°		mm	2000
PERFORMANCES	5.1	Travel speed laden/unladen		Km/h	9 / 16
	5.5	Drawbar pull laden		N	-
	5.5.1	Drawbar pull unladen		N	1900
	5.6	Max. Drawbar pull laden/unladen		N	- / 6200
	5.7	Gradeability laden/unladen		%	See chart
	5.8	Max. Gradeability laden/unladen		%	See chart
	5.10	Service / Parking brake (I=Hydraulic E=Electromagn. M=Mechanical)			I / E
	5.10.1	Type of service brake front/rear			drum / drum
MOTOR	6.1	Drive motor rating S2=60 min		kW	5
	6.1.1	Hydrauling steering motor rating S2=60 min		kW	0,55
	6.3	Battery according to DIN 43531 / 35 / 36 A, B, C, no			43531 A
	6.4	Battery voltage	U	V	48
	6.4.1	Battery rated capacity	K <sub>5</sub>	Ah	315 - 345 - <b>375</b>
	6.5	Battery weighth		Kg	536 - 550 - <b>580</b>
	6.6	Energy consumption (VDI cycle)		kWh/h	-
OTHER DATA	8.1	Drive Control			Inverter AC
	8.4	Sound level at driver's ear according to DIN 12053		dB(A)	69
	8.5	Towing coupling, type DIN			-

READING EXAMPLE:  
 CHARGE = 1 TONS  
 GRADIENT = 13 %  
 DRAWBAR PULL = 3330 N  
 SPEED = 7 Km/h  
 MAX PRACTICABLE RAMP LENGTH = 2000 m

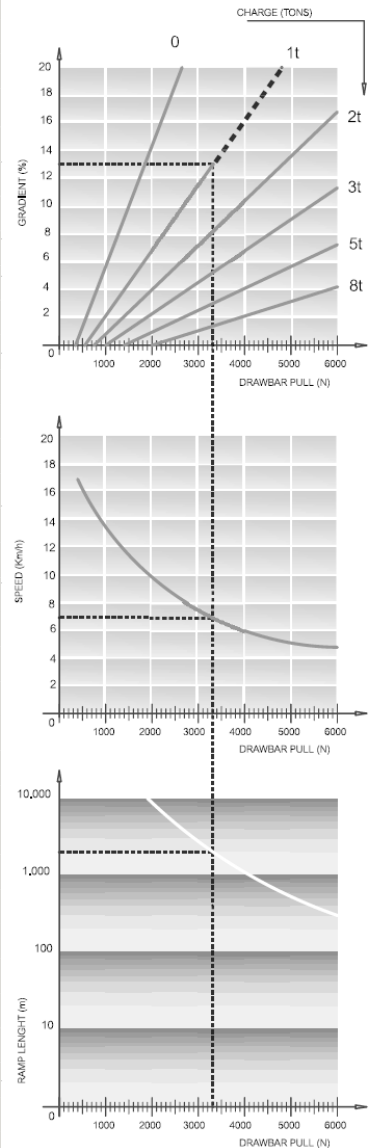

As per VDI guidelines 2198, this datasheet applies to standard electric tractor / platform truck only. Dimensions are not binding and can be changed in any moment. The performances must be intended for brand new machines, after having completed the running-in tested in San Donato Milanese Factory in normal climatic conditions. Performances and weight are to be intended with standard motors and battery (reported in bold) and with pneumatic tires. Some data can vary according to different equipments.

## 4-wheel electric tow tractor TE152

Towing Capacity 15000 kg



4-wheel tow tractor, man on board, with rear-wheel drive. Ideal for all intense duties - both indoors and outdoors. Loading capacity of wide rear platform 200 kg.

- “Shock resistant” **supporting perimeter chassis** ensures maximum exploitation of induction motor torque.
- **Suspensions:** rubberised steel coil springs in the front, SUMOR springs in the rear.
- **Drum service brake** acting on 4 wheels with twofold braking system. Electromagnetic parking brake. Preset electrical **braking**, operating automatically when accelerator pedal is released, with first stroke of brake pedal and on reversing direction.
- Standard hydraulic **steering**.
- **2 operators on board.** Optimised driving position for maximum comfort and efficiency, low step-on platform for comfortable access as well as user-friendly and ergonomic dashboard.
- **“Man on board” device** with seat occupancy sensor. Available in the basic version, with weather protection roof with front windscreen and electric wiper PVC canvas doors or cab with hinged or sliding side doors available.

- **Lighting system:** 2 front beams (dipped-beam/main-beam), 2 front turn indicators, 2 rear turn indicators, 2 rear beams (tail/ brake lights). Full LED technology Horn. Flashing light, reversing light and blue lights as well as cab lights available upon request.
- **Digital dashboard** with battery charge indicator, fault detection, speedometer and hour meter 24 V DC/DC converter for auxiliary services.
- **2 induction motors** equipped with encoder thermal probes and negative electromagnetic parking brake.
- **Electronic speed control of AC motor** with energy recovery during deceleration and braking. Several towing hitches available. Rear inching control to ease coupling operations.
- **Battery** DIN 43531B 48 V - available capacity 525Ah, 575Ah and 625Ah. Battery fitted behind driving position for fast replacement from above. Standard paint finish: chassis dark grey RAL 7021/body light grey RAL 7035. Other colours available upon request.

All parts are easy to access for fast and effective maintenance. Lower costs due to AC technology and modular design.

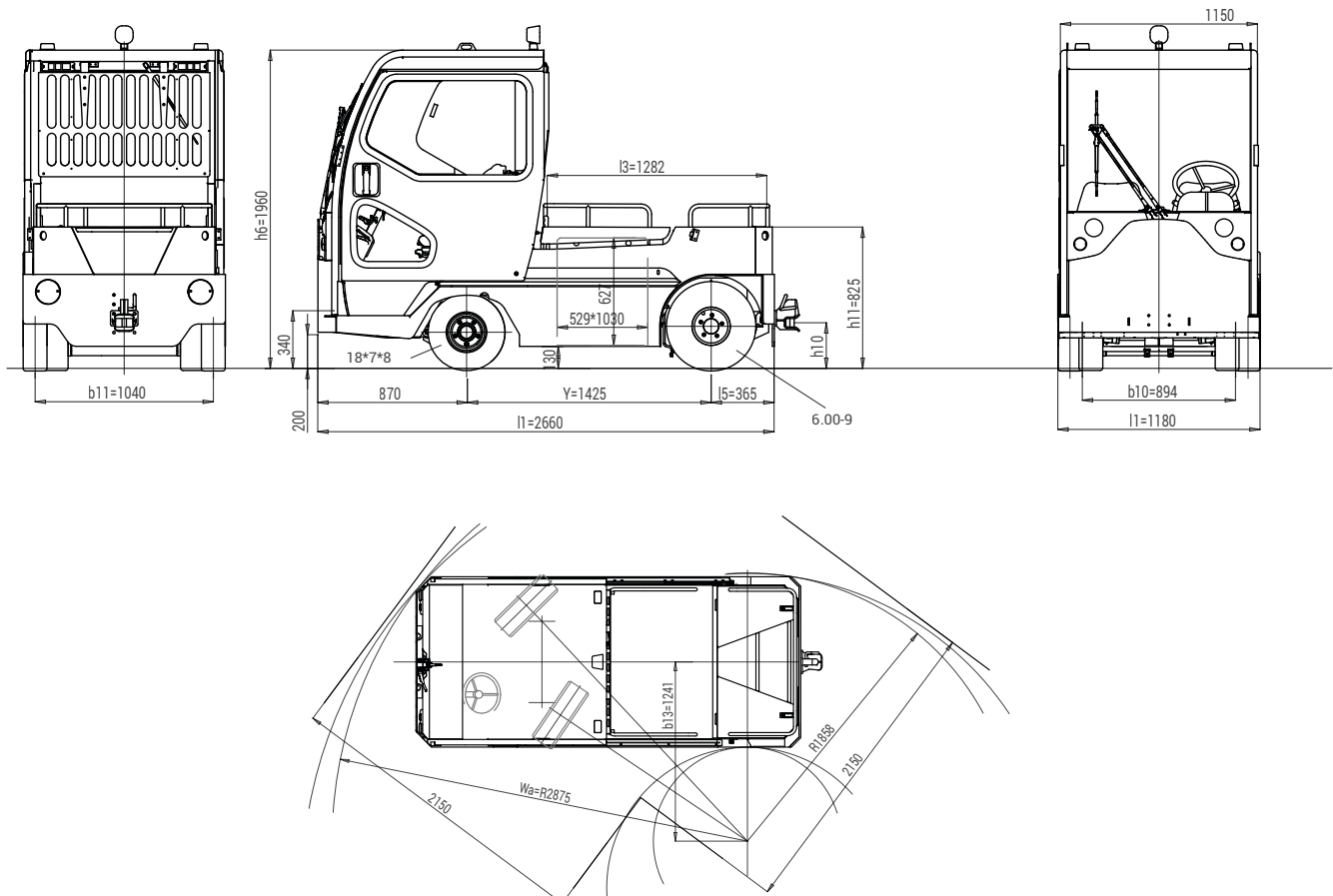



FEATURES	1.1	Manufacturer			SIMAI S.p.A.
	1.2	Model			TE152
	1.3	Drive			electric
	1.4	Operator Type			Sitting driver
	1.5	Load Capacity	Q	t	0,2
	1.5.1	Towing Capacity	Q	t	15
	1.7	Rated Drawbar pull	F	N	3000
	1.9	Wheelbase	Y	mm	1425
	WEIGHT	2.1	Service weight (w/battery)		Kg
2.2		Axle loading laden front/rear (with operator 80 kg. each)		Kg	1440 / 1170
2.3		Axle loading unladen front/rear		Kg	1290 / 970
TIRES, CHASSIS	3.1	Tyres:Cushion(Cu),Superelastic(SE), Pneus(Pn) Poliurethane (PE)			SE/Pn
	3.2	Tyre size front			18x7x8
	3.3	Tyre size rear			6.00-9
	3.5	Wheels nr Front/Rear (X=motive)			2 / 2X
	3.6	Tread front	b <sub>10</sub>	mm	894
	3.7	Tread rear	b <sub>11</sub>	mm	1040
	DIMENSIONS	4.7	Height of roof/cabin	h <sub>6</sub>	mm
4.8		Seat height	h <sub>7</sub>	mm	850
4.8.1		Step on platform height		mm	340
4.12		Coupling height	h <sub>10</sub>	mm	240 - 295 - 350 - 405
4.13		Loading height (min / MAX)	h <sub>11</sub>	mm	825
4.16		Platform length	l <sub>3</sub>	mm	1282
4.17		Rear overhang	l <sub>5</sub>	mm	365
4.18		Platform width	b <sub>9</sub>	mm	880
4.19		Overall length	l <sub>1</sub>	mm	2660
4.21		Overall width	b <sub>1</sub>	mm	1180
4.32		Ground clearance - centre of wheelbase	m <sub>2</sub>	mm	130
4.35		Turning radius front	Wa	mm	2875
4.35.1		Turning radius rear		mm	1858
4.36		Turning radius inner	b <sub>13</sub>	mm	1241
4.36.1	Aisle width when turning 90°		mm	2150	
PERFORMANCES	5.1	Travel speed laden/unladen		Km/h	11 / 21
	5.5	Drawbar pull laden		N	-
	5.5.1	Drawbar pull unladen		N	3000
	5.6	Max. Drawbar pull laden/unladen		N	- / 10500
	5.7	Gradeability laden/unladen		%	See chart
	5.8	Max. Gradeability laden/unladen		%	See chart
	5.10	Service / Parking brake (I=Hydraulic E=Electromagn. M=Mechanical)			I / E
5.10.1	Type of service brake front/rear			drum/wet brakes	
MOTOR	6.1	Drive motor rating S2=60 min		kW	2 x 6,6
	6.1.1	Hydrauling steering motor rating S2=60 min		kW	0,6 (Ac)
	6.3	Battery according to DIN 43531 / 35 / 36 A, B, C, no			43531 B
	6.4	Battery voltage	U	V	48
	6.4.1	Battery rated capacity	K <sub>5</sub>	Ah	525 - 575 - <b>625</b>
	6.5	Battery weight		Kg	812 - 857 - <b>898</b>
6.6	Energy consumption (VDI cycle)		kWh/h	-	
OTHER DATA	8.1	Drive Control			2 inverter AC
	8.4	Sound level at driver's ear according to DIN 12053		dB(A)	69
	8.5	Towing coupling, type DIN			-

READING EXAMPLE:  
 CHARGE = 2 TONS  
 GRADIENT = 15 %  
 DRAWBAR PULL = 6650 N  
 SPEED = 8 Km/h  
 MAX PRACTICABLE RAMP LENGHT = 1300 m

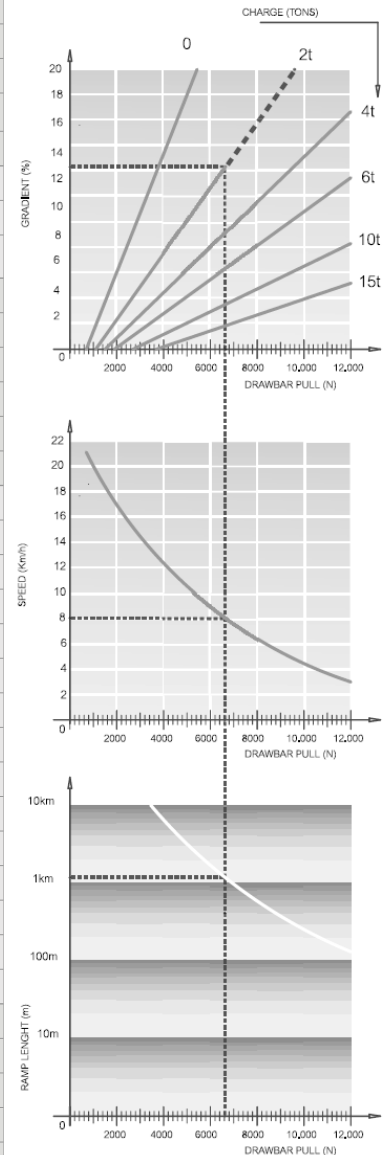

As per VDI guidelines 2198, this datasheet applies to standard electric tractor / platform truck only. Dimensions are not binding and can be changed in any moment. The performances must be intended for brand new machines, after having completed the running-in tested in San Donato Milanese Factory in normal climatic conditions. Performances and weight are to be intended with standard motors and battery (reported in bold) and with pneumatic tires. Some data can vary according to different equipments.

# CESAB Simai

## 4-Wheel electric tow tractor TE252 / TE293

Towing capacity 25000 kg / 29000 kg



4-wheel tow tractor, with on-board operator. Heavy-duty high-performance and long-range truck for industrial and airport duties. Despite its small size and turning radius, the **TE252** has a 25-tonne towing capacity. **TE293** version with 29-tonne towing capacity. Loading capacity of wide rear platform 200 kg.

- New **supporting perimeter chassis** ensures maximum exploitation of AC motor torque and optimum stability.
- **Suspensions:** steel coil springs, stabiliser bar and hydraulic shock absorbers in the front and in the rear.
- **Service brake pedal**, acting on 4 wheels - with twofold braking system. Front disk brakes and rear oil-bath multiple-disk brakes.  
Standard negative hydraulic parking brake.  
Preset electrical braking, operating automatically when accelerator pedal is released, with first stroke of brake pedal and when reversing direction.
- Standard hydraulic **steering**.
- **2 operators on board.** Comfortable driving position in the front ensures excellent front and rear visibility. Standard mechanical suspension seats. Easy access to driving position thanks to low step-on platform.
- **"Man on board" device** with pedal. Telemèchanique pedal - optionally with seat occupancy sensor. Rear clearance lights. Horn.
- **Digital dashboard** with battery charge indicator, fault detection, speedometer, steering angle indicator, speed profile selection, odometer and hour meter.

- **2 new generation AC motors** directly integrated in the gearboxes, one for each wheel. Electronic differential system.
- **Electronic AC control** with energy recovery and braking during deceleration.
- Several towing hitches available. Rear inching control to ease coupling operations.
- DIN 43536A 80 V battery with 620 Ah capacity - fast vertical replacement.

### Available options:

Pneumatic, superelastic or non-marking **tyres**. **Full cab** with sliding side doors, flat front windscreen, rear window, electric wiper, sun visor, integrated light system in the cabin with 2 front lights (dipped-beam/main-beam), 2 front turn indicators, rear lights on the back of the cab in high anti-collision position (position/brake/reversing lights/turn indicators), 2 exterior rearview mirrors – full-LED lights. Available also without doors, with canvas doors or hinged doors.

Electric **heater**; air conditioning (cooling).

**Flashing light** and blue safety light.

Standard paint finish: chassis dark grey RAL 7021/body light grey RAL 7035. Other colours available upon request.

All parts are easy to access for fast and effective maintenance. Lower costs due to AC technology and modular design.

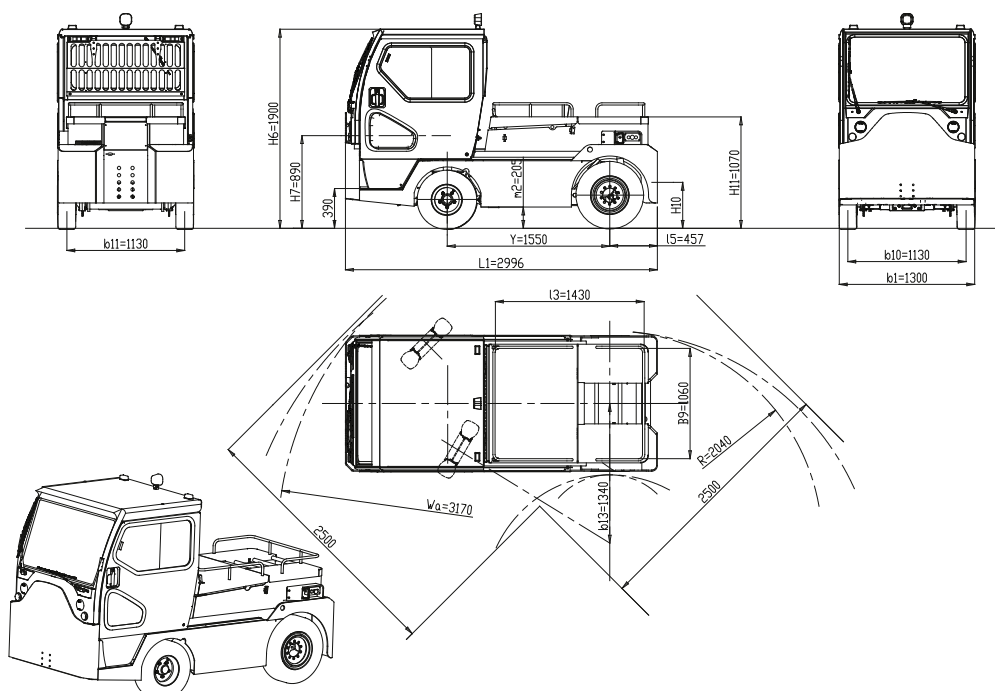

# TE252 / TE293



FEATURES	1.1	Manufacturer			SIMAI S.p.A.	SIMAI S.p.A.
	1.2	Model			TE252	TE293
	1.3	Drive			Electric	Electric
	1.4	Operator Type			Sitting driver	Sitting driver
	1.5	Load Capacity	Q	t	0,2	0,2
	1.5.1	Towing Capacity	Q	t	25	29
	1.7	Rated Drawbar pull	F	N	5800	5800
	1.9	Wheelbase	Y	mm	1550	1550
WEIGHTS	2.1	Service weight (w/battery)		Kg	3670	4000
	2.2	Axle loading laden front/rear (with operator 80 kg. each)		Kg	2231 / 1908	2220 / 2140
	2.3	Axle loading unladen front/rear		Kg	1900 / 1770	2020 / 1980
TYRES - CHASSIS	3.1	Tyres:Cushion(Cu),Superelastic(SE), Pneus(Pn) Poliurethane (PE)			SE/Pn	SE/Pn
	3.2	Tyre size front			6.50-10	6.50-10
	3.3	Tyre size rear			7.00-12	7.00-12
	3.5	Wheels nr. Front/Rear (X=motive)			2 / 2X	2 / 2X
	3.6	Tread front	b <sub>10</sub>	mm	1130	1130
	3.7	Tread rear	b <sub>11</sub>	mm	1130	1130
	DIMENSIONS	4.7	Height of roof/cabin	h <sub>6</sub>	mm	1900
4.8		Seat height	h <sub>7</sub>	mm	890	890
4.8.1		Step on platform height		mm	390	390
4.12		Coupling height	h <sub>10</sub>	mm	310 - 380 - 450 - 520	310 - 380 - 450 - 520
4.13		Loading height (min / MAX)	h <sub>11</sub>	mm	1070	1070
4.16		Platform length	l <sub>3</sub>	mm	1430	1430
4.17		Rear overhang	l <sub>5</sub>	mm	457	457
4.18		Platform width	b <sub>9</sub>	mm	1060	1060
4.19		Overall length	l <sub>1</sub>	mm	2996	2996
4.21		Overall width	b <sub>1</sub>	mm	1300	1300
4.32		Ground clearance - centre of wheelbase	m <sub>2</sub>	mm	205	205
4.35		Turning radius front	Wa	mm	3170	3170
4.35.1		Turning radius rear		mm	2040	2040
4.36		Turning radius inner	b <sub>13</sub>	mm	1340	1340
4.36.1		Aisle width when turning 90°		mm	2500	2500
PERFORMANCES		5.1	Travel speed laden/unladen		Km/h	14 / 25
	5.5	Drawbar pull laden		N	-	-
	5.5.1	Drawbar pull unladen		N	5800	5800
	5.6	Max. Drawbar pull laden/unladen		N	- / 18000	- / 20000
	5.7	Gradeability laden/unladen		%	See chart	See chart
	5.8	Max. Gradeability laden/unladen		%		
	5.10	Service / Parking brake (I=Hydraulic E=Electromagn. M=Mechanical)			I / I	I / I
	5.10.1	Type of service brake front/rear			Disk / wet brakes	Disk / wet brakes
MOTOR	6.1	Drive motor rating S2=60 min		kW	2*10	2*10
	6.1.1	Hydrauling steering motor rating S2=60 min		kW	0,6	0,6
	6.3	Battery according to DIN 43531 / 35 / 36 A, B, C, no			DIN 43536A	DIN 43536A
	6.4	Battery voltage	U	V	80	80
	6.4.1	Battery rated capacity	K <sub>s</sub>	Ah	620	620
	6.5	Battery weight		Kg	1565	1565
	6.6	Energy consumption (VDI cycle)		kWh/h	-	-
OTHER DATA	8.1	Drive Control			inverter AC	inverter AC
	8.4	Sound level at driver's ear according to DIN 12053		dB(A)	69	69
	8.5	Towing coupling, type DIN			-	-

As per VDI guidelines 2198, this datasheet applies to standard electric tractor / platform truck only. Dimensions are not binding and can be changed in any moment. The performances must be intended for brand new machines, after having completed the running-in tested in San Donato Milanese Factory in normal climatic conditions. Performances and weight are to be intended with standard motors and battery (reported in bold) and with extra-elastic tires. Some data can vary according to different equipments.

# CESAB Simai

## 4-wheel electric tow tractor TE301

Towing Capacity 30000 kg



4-wheel tow tractor, man on board. Heavy-duty high-performance and long-range truck for industrial and airport duties. Despite its small size and turning radius, the TE300R has a high towing capacity. Driving position is located backwards ensuring optimum weight distribution and excellent stability. Loading capacity of front platform 80 kg.

- "Shock resistant" **supporting perimeter chassis** ensures maximum exploitation of induction motor torque.
- **Suspensions:** steel coil springs, stabiliser bar and shock absorbers in the front and in the rear
- **Drum service brake** acting on 4 wheels - with twofold braking system. Front disk brakes and rear oil-bath multiple-disk brakes. Mechanical lever-type parking brake - negative hydraulic brake available upon request. Preset electrical **braking**, operating automatically when accelerator pedal is released, with first stroke of brake pedal and on reversing direction.
- Standard hydraulic **steering**.
- **2 operators on board.** Comfortable driving position ensures excellent visibility both to the front and to the rear towing hitch.
- **"Man on board" device** with seat occupancy sensor. Available in basic version, with weather protection roof with front windscreen and electric wipers. PVC canvas doors or cab with hinged side doors available.

- **Lighting system:** 2 front lights (position/dipped-beam/main-beam), 2 front turn indicators, 2 rear turn indicators, 2 rear lights (position/brake lights), 2 reversing lights. Horn. Flashing light and blue lights available upon request.
- **Digital dashboard** with battery charge indicator, fault detection, speedometer and hour meter. 24 V DC/DC converter for auxiliary services.
- **Induction motor** with through shaft integrated into driveline.
- **Electronic speed control of AC motor** with energy recovery during deceleration and braking. Several towing hitches available. Rear inching control to ease coupling operations.
- **Battery DIN 43536A, 80 V – available capacity 480 - 620Ah.** Battery in the front of the driver's cab for fast replacement from the side. Standard paint finish: chassis dark grey RAL 7021/body light grey RAL 7035. Other colours available upon request.

All parts are easy to access for fast and effective maintenance. Lower costs due to AC technology and modular design.

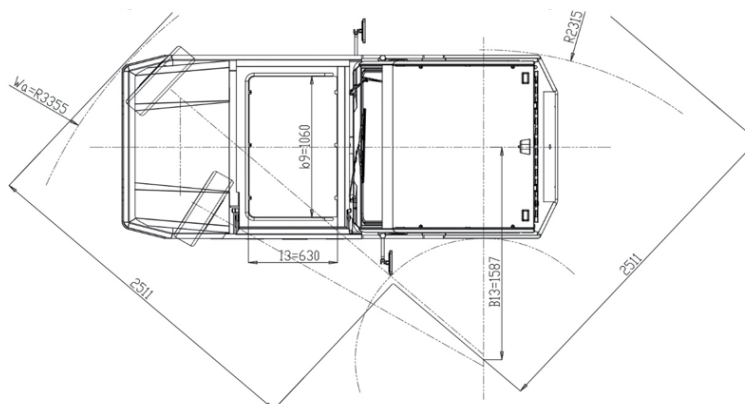
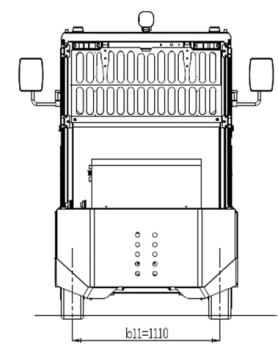
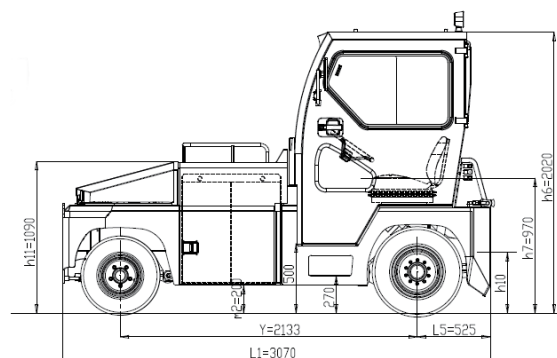
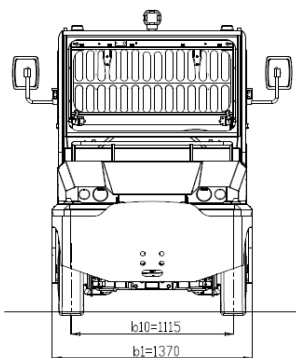

FEATURES	1.1	Manufacturer			SIMAI S.p.A.	
	1.2	Model			TE301	
	1.3	Drive			Electric	
	1.4	Operator Type			Sitting driver	
	1.5	Load Capacity	Q	t	0,1	
	1.5.1	Towing Capacity	Q	t	30	
	1.7	Rated Drawbar pull	F	N	6000	
1.9	Wheelbase	Y	m	2143		
WEIGHT	2.1	Service weight (w/battery)		Kg	4200	
	2.2	Axle loading laden front/rear (with operator 80 kg. each)		Kg	2070 / 2390	
	2.3	Axle loading unladen front/rear		Kg	1980 / 2220	
TIRES, CHASSIS	3.1	Tyres:Cushion(Cu),Superelastic(SE), Pneus(Pn) Poliurethane (PE)			SE/Pn	
	3.2	Tyre size front			6.50-10	
	3.3	Tyre size rear			7.00-12	
	3.5	Wheels nr. Front/Rear (X=motive)			2/2X	
	3.6	Tread front	$b_{10}$	mm	1115	
	3.7	Tread rear	$b_{11}$	mm	1110	
	DIMENSIONS	4.7	Height of roof/cabin	$h_6$	mm	2032
4.8		Seat height	$h_7$	mm	986	
4.8.1		Step on platform height		mm	512	
4.12		Coupling height	$h_{10}$	mm	355-410-465-520-575	
4.13		Loading height (min / MAX)	$h_{11}$	mm	1110	
4.16		Platform length	$l_3$	mm	630	
4.17		Rear overhang	$l_5$	mm	525	
4.18		Platform width	$b_9$	mm	1060	
4.19		Overall length	$l_1$	mm	3080	
4.21		Overall width	$b_1$	mm	1377	
4.32		Ground clearance - centre of wheelbase	$m_2$	mm	200	
4.35		Turning radius front	$W_a$	mm	3355	
4.35.1		Turning radius rear		mm	2315	
4.36		Turning radius inner	$b_{13}$	mm	1587	
4.36.1		Aisle width when turning 90°		mm	2511	
PERFORMANCES	5.1	Travel speed laden/unladen		Km/h	12 / 25	
	5.5	Drawbar pull laden		N	-	
	5.5.1	Drawbar pull unladen		-	-	
	5.6	Max. Drawbar pull laden/unladen		N	- / 20000	
	5.7	Gradeability laden/unladen		%	See chart	
	5.8	Max. Gradeability laden/unladen		%	See chart	
	5.10	Service / Parking brake (I=Hydraulic E=Electromagn. M=Mechanical)			I / M	
5.10.1	Type of service brake front/rear			disk / mult. disks		
MOTOR	6.1	Drive motor rating S2=60 min			2 x 10	
	6.1.1	Hydrauling steering motor rating S2=60 min		kW	1	
	6.3	Battery according to DIN 43531 / 35 / 36 A, B, C, no				43536A
	6.4	Battery voltage	U	V		80
	6.4.1	Battery rated capacity	$K_5$	Ah		480 - 620
	6.5	Battery weighth		Kg		1565
	6.6	Energy consumption (VDI cycle)		kWh/h		-
OTHER DATA	8.1	Drive Control			Inverter AC	
	8.4	Sound level at driver's ear according to DIN 12053		dB(A)	69	
	8.5	Towing coupling, type DIN				-

#### READING EXAMPLE

LOADING CAPACITY + TRAILED

LOAD = 2 ton + [2 ton]

GRADIENT (i) = 4 %

DRAWBALL PULL (F) = 4000 N

SPEED (V0) = 10 [Km/h]

MAX PRACTICABLE RAMP LENGHT (s) = 7,5 km

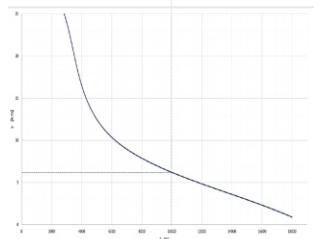
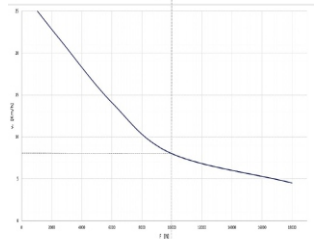
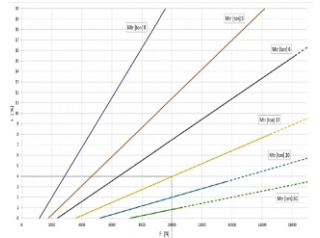

As per VDI guidelines 2198, this datasheet applies to standard electric tractor / platform truck only. Dimensions are not binding and can be changed in any moment. The performances must be intended for brand new machines, after having completed the running-in tested in San Donato Milanese Factory in normal climatic conditions. Performances and weight are to be intended with standard motors and battery (reported in bold) and with pneumatic tires. Some data can vary according to different

# CESAB Simai

## 4-wheel electric tow tractor TE501

Towing Capacity 50000 kg

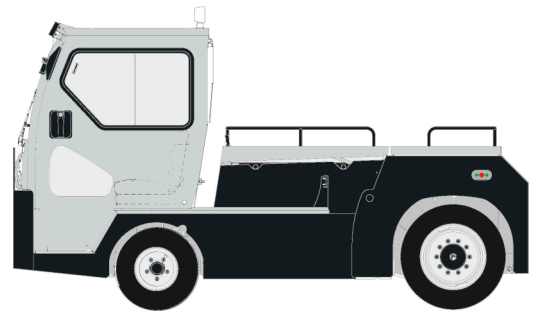

4-wheel tow tractor, with on-board operator. Heavy-duty high-performance and long-range truck for industrial and airport duties. Despite its small size and turning radius, the TE501 has a 50-tonne towing capacity. Loading capacity of wide rear platform 200 kg.

- New **supporting perimeter chassis** ensures maximum exploitation of AC motor torque and optimum stability
- **Suspensions:** steel coil springs, stabiliser bar and shock absorbers in the front, rubberised springs with hydraulic shock absorber in the rear.
- **Service brake pedal**, acting on 4 wheels - with twofold braking system. Front disk brakes and rear oil-bath multiple-disk brakes.  
Standard negative hydraulic parking brake.  
Preset electrical **braking**, operating automatically when accelerator pedal is released, with first stroke of brake pedal and when reversing direction.
- Standard hydraulic **steering**.
- **2 operators on board**. Comfortable driving position in the front ensures excellent front and rear visibility. Standard mechanical suspension seats. Easy access to driving position thanks to low step-on platform.
- **"Man on board" device** with seat occupancy sensor. Horn.
- **Digital dashboard** with battery charge indicator, fault detection, speedometer, steering angle indicator, speed profile selection, odometer and hour meter.

- **New generation AC electric motor.**
- **Electronic AC control** with energy recovery and braking during deceleration.
- Several towing hitches available. Rear inching control to ease coupling operations.
- DIN 43536A 80 V battery with 620 Ah capacity - fast vertical replacement.

### Available options:

Pneumatic, superelastic or non-marking **tyres**. **Full cab** with sliding side doors, flat front windscreen, rear window, electric wiper, sun visor, integrated light system in the cabin with 2 front lights (dipped-beam/main-beam), 2 front turn indicators, rear lights on the back of the cab in high anti-collision position (position/brake/reversing lights/turn indicators), 2 exterior rearview mirrors – full-LED lights. Available also without doors, with canvas doors or hinged doors.

Electric **heater**; air conditioning (cooling).

**Flashing light** and blue safety light.

Standard paint finish: chassis dark grey RAL 7021/body light grey RAL 7035. Other colours available upon request.

All parts are easy to access for fast and effective maintenance. Lower costs due to AC technology and modular design.

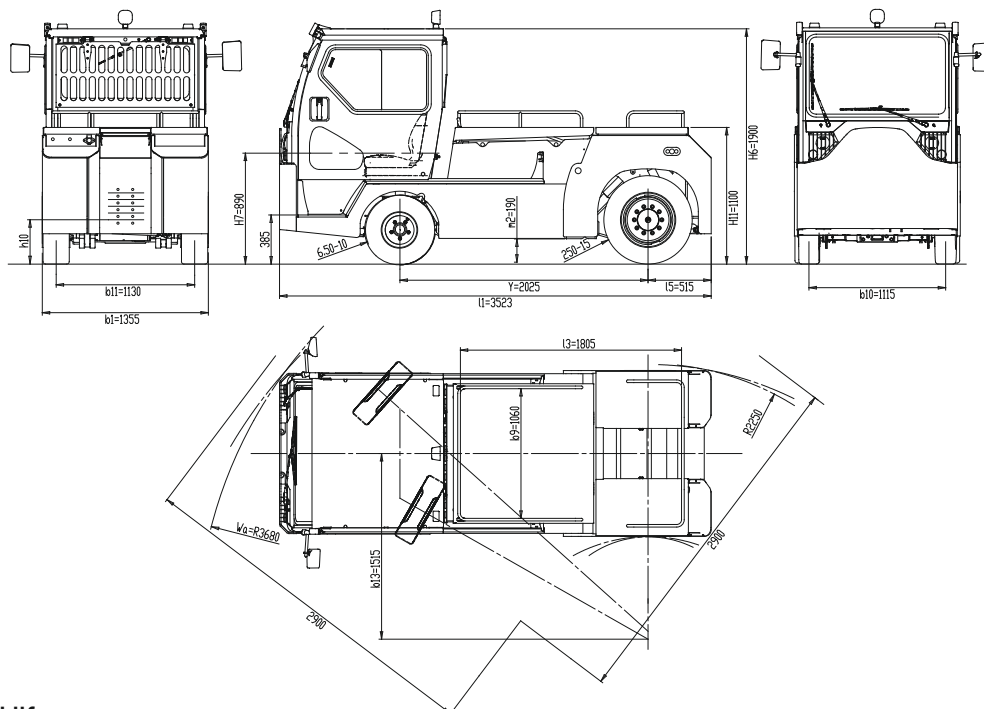

FEATURES	1.1	Manufacturer			SIMAI S.p.A.
	1.2	Model			TE501
	1.3	Drive			Electric
	1.4	Operator Type			Sitting driver
	1.5	Load Capacity	Q	t	0,2
	1.5.1	Towing Capacity	Q	t	50
	1.7	Rated Drawbar pull	F	N	10000
	1.9	Wheelbase	Y	mm	2025
	WEIGHTS	2.1	Service weight (w/battery)		Kg
2.2		Axle loading laden front/rear (with operator 80 kg. each)		Kg	2570 / 3490
2.3		Axle loading unladen front/rear		Kg	2370 / 3330
TYRES - CHASSIS	3.1	Tyres:Cushion(Cu),Superelastic(SE), Pneus(Pn) Poliurethane (PE)			SE/Pn
	3.2	Tyre size front			6.50-10
	3.3	Tyre size rear			250-15
	3.5	Wheels nr Front/Rear (X=motive)			2 / 2X
	3.6	Tread front	b <sub>10</sub>	mm	1115
	3.7	Tread rear	b <sub>11</sub>	mm	1130
	DIMENSIONS	4.7	Height of roof/cabin	h <sub>6</sub>	mm
4.8		Seat height	h <sub>7</sub>	mm	890
4.8.1		Step on platform height		mm	385
4.12		Coupling height	h <sub>10</sub>	mm	345 - 400 - 455 - 510 -565
4.13		Loading height (min / MAX)	h <sub>11</sub>	mm	1100
4.16		Platform length	l <sub>3</sub>	mm	1800
4.17		Rear overhang	l <sub>5</sub>	mm	515
4.18		Platform width	b <sub>9</sub>	mm	1060
4.19		Overall length	l <sub>1</sub>	mm	3523
4.21		Overall width	b <sub>1</sub>	mm	1355
4.32		Ground clearance - centre of wheelbase	m <sub>2</sub>	mm	190
4.35		Turning radius front	Wa	mm	3680
4.35.1		Turning radius rear		mm	2250
4.36		Turning radius inner	b <sub>13</sub>	mm	1515
4.36.1	Aisle width when turning 90°		mm	2900	
PERFORMANCES	5.1	Travel speed laden/unladen		Km/h	7 / 16
	5.5	Drawbar pull laden		N	-
	5.5.1	Drawbar pull unladen		N	10000
	5.6	Max. Drawbar pull laden/unladen		N	- / 29000
	5.7	Gradeability laden/unladen		%	See chart
	5.8	Max. Gradeability laden/unladen		%	
	5.10	Service / Parking brake (I=Hydraulic E=Electromagn. M=Mechanical)			I / I
	5.10.1	Type of service brake front/rear			Disk / wet brakes
MOTOR	6.1	Drive motor rating S2=60 min		kW	26
	6.1.1	Hydrauling steering motor rating S2=60 min		kW	1
	6.3	Battery according to DIN 43531 / 35 / 36 A, B, C, no			DIN 43536A
	6.4	Battery voltage	U	V	80
	6.4.1	Battery rated capacity	K <sub>5</sub>	Ah	840 - 930
	6.5	Battery weight		Kg	<b>2208 - 2288</b>
	6.6	Energy consumption (VDI cycle)		kWh/h	-
OTHER DATA	8.1	Drive Control			inverter AC
	8.4	Sound level at driver's ear according to DIN 12053		dB(A)	69
	8.5	Towing coupling, type DIN			-

As per VDI guidelines 2198, this datasheet applies to standard electric tractor / platform truck only. Dimensions are not binding and can be changed in any moment. The performances must be intended for brand new machines, after having completed the running-in tested in San Donato Milanese Factory in normal climatic conditions. Performances and weight are to be intended with standard motors and battery (reported in bold) and with extra-elastic tires. Some data can vary according to different equipments.

## Electric platform truck PE15.1

Load Capacity 1500 kg

Towing Capacity 10000 kg



4-wheel platform truck, man on board, with rear-wheel drive. Extremely compact and easy to drive, ideal for all duties – both indoors and outdoors, even on long distances. The platform of the PE15.1 truck can be completed with additional equipment

- **Central chassis.**
- Steel plate **platform** size 1.700x1.100 mm – other sizes available upon request.
- **Suspensions:** front and rear axles, front with steel helical springs, rear with steel helical springs, hydraulic shock-absorbers and stabilizer bar.
- **Service brake** on all 4 wheels, front drum brakes, rear wet disks (multiple disks in oil bath in a closed compartment – maintenance – free). Electronic brake engaged when releasing the accelerator pedal and/or pushing the first stroke of the brake pedal. Hydraulic service brake engaged when pushing the brake pedal. Double circuit: is divided in two parallel parts, if one fails, the other keeps working allowing to bring unit to maintenance/recovery point in safety.
- **Standard hydraulic steering.**
- **1 operator on board.** Optimised driving position for maximum comfort and efficiency as well as user-friendly and ergonomic dashboard. Passenger seat available upon request.
- **“Man on board” device under driver’s seat.** Available in basic version, with weather protection roof with front windscreen and electric wipers. PVC canvas doors or cab with hinged side doors available.

- **Lighting system:** 2 front lights (position/dipped-beam/main-beam), 2 front turn indicators, 2 rear turn indicators, 2 rear lights (position/brake lights). Horn. Flashing light, reversing light and blue lights available upon request.
  - **Digital dashboard** with the battery charge indicator, fault detection, speedometer and hour meter. 24 V DC/DC converter for auxiliary services.
  - **Induction motor** equipped with encoder, thermal probes and negative electromagnetic parking brake with manual brake disengage lever.
  - **Electronic speed control of AC motor** with energy recovery during deceleration and braking. Towing hitch available upon request.
  - **Battery DIN 43531A 48 V 420-460-500Ah**  
Standard paint finish: chassis dark grey RAL 7021 /body light grey RAL 7035. Other colours available upon request.
- All parts are easy to access for fast and effective maintenance, Lower costs due to AC technology and modular design.

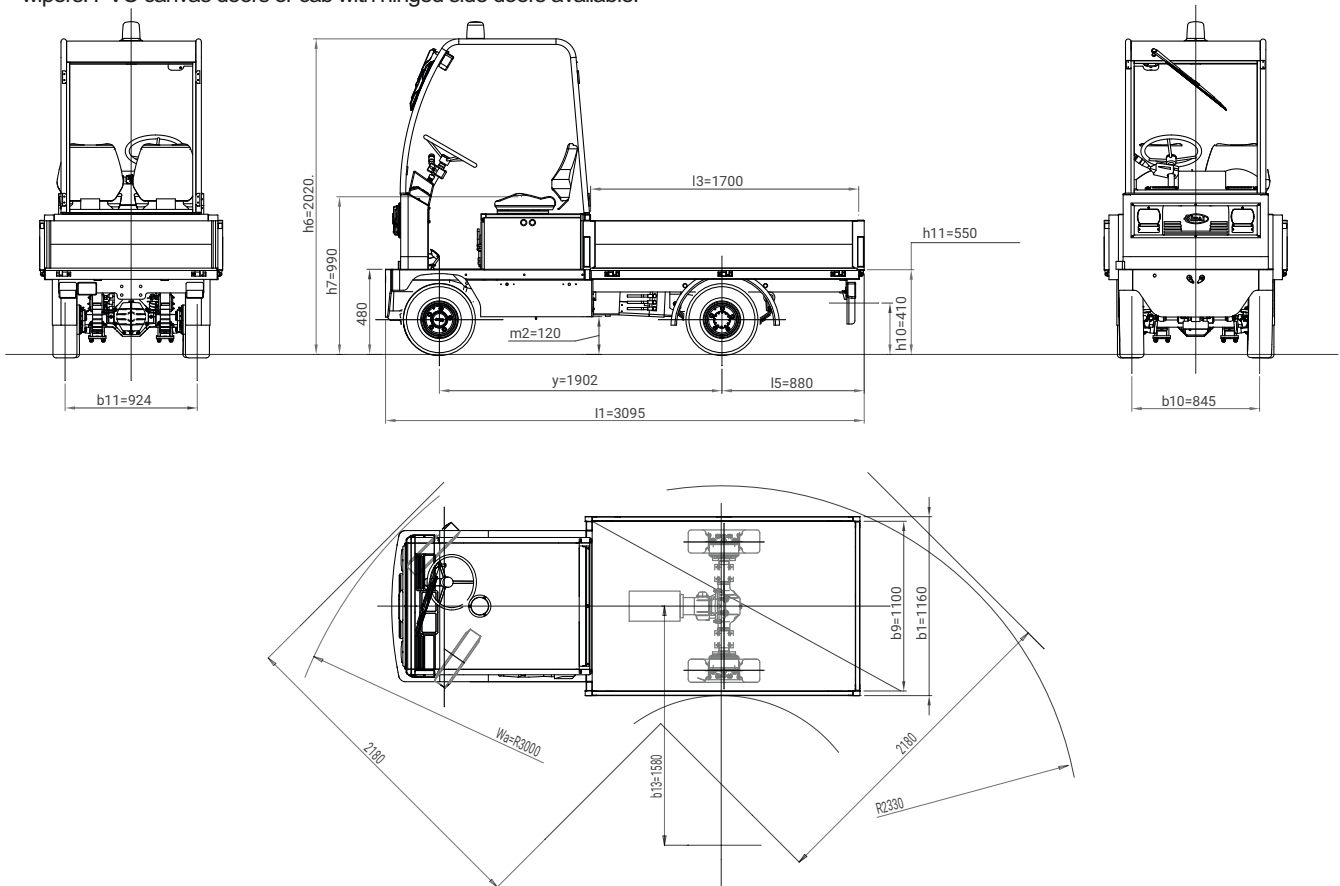



FEATURES	1.1	Manufacturer			SIMAI S.p.A.
	1.2	Model			PE15.1
	1.3	Drive			electric
	1.4	Operator Type			Sitting driver
	1.5	Load Capacity	Q	t	1,5
	1.5.1	Towing Capacity	Q	t	10
	1.7	Rated Drawbar pull	F	N	2200
	1.9	Wheelbase	Y	mm	1900
	WEIGHT	2.1	Service weight (w/battery)		Kg
2.2		Axle loading laden front/rear (with operator 80 kg. each)		Kg	1000 / 2220
2.3		Axle loading unladen front/rear		Kg	925 / 720
TIRES, CHASSIS	3.1	Tyres:Cushion(Cu),Superelastic(SE), Pneus(Pn) Poliurethane (PE)			SE/Pn
	3.2	Tyre size front			4.00-8
	3.3	Tyre size rear			18x7-8
	3.5	Wheels nr. Front/Rear (X=motive)			2/2X
	3.6	Tread front	b <sub>10</sub>	mm	845
	3.7	Tread rear	b <sub>11</sub>	mm	884
	DIMENSIONS	4.7	Height of roof/cabin	h <sub>6</sub>	mm
4.8		Seat height	h <sub>7</sub>	mm	990
4.8.1		Step on platform height		mm	480
4.12		Coupling height	h <sub>10</sub>	mm	410
4.13		Loading height (min / MAX)	h <sub>11</sub>	mm	550
4.16		Platform length	l <sub>3</sub>	mm	1700
4.17		Rear overhang	l <sub>5</sub>	mm	850
4.18		Platform width	b <sub>9</sub>	mm	1100
4.19		Overall length	l <sub>1</sub>	mm	3065
4.21		Overall width	b <sub>1</sub>	mm	1160
4.32		Ground clearance - centre of wheelbase	m <sub>2</sub>	mm	120
4.35		Turning radius front	Wa	mm	2850
4.35.1		Turning radius rear		mm	2100
4.36		Turning radius inner	b <sub>13</sub>	mm	1300
4.36.1		Aisle width when turning 90°		mm	2180
PERFORMANCES		5.1	Travel speed laden/unladen		Km/h
	5.5	Drawbar pull laden		N	- - -
	5.5.1	Drawbar pull unladen		N	2200
	5.6	Max. Drawbar pull laden/unladen		N	- / 8000
	5.7	Gradeability laden/unladen		%	See chart
	5.8	Max. Gradeability laden/unladen		%	See chart
	5.10	Service / Parking brake (I=Hydraulic E=Electromagn. M=Mechanical)			I / E
5.10.1	Type of service brake front/rear			Drum / Wet disk brakes	
MOTOR	6.1	Drive motor rating S2=60 min		kW	2 x 6,6
	6.1.1	Hydrauling steering motor rating S2=60 min		kW	0,6 AC
	6.3	Battery according to DIN 43531 / 35 / 36 A, B, C, no			43531 A
	6.4	Battery voltage	U	V	48
	6.4.1	Battery rated capacity	K <sub>5</sub>	Ah	420 - 460 - <b>500</b>
	6.5	Battery weight		Kg	667 - 700 - <b>731</b>
OTHER DATA	6.6	Energy consumption (VDI cycle)		kWh/h	-
	8.1	Drive Control			inverter A/C
	8.4	Sound level at driver's ear according to DIN 12053		dB(A)	69
	8.5	Towing coupling, type DIN			-

**READING EXAMPLE**  
 LOADING CAPACITY + TRAILED  
 LOAD = 1,5 tons + [2 ton]  
 GRADIENT (j) = 5 %  
 DRAWBALL PULL (F) = 4000 N  
 SPEED (V0) = 10 [Km/h]  
 MAX PRACTICABLE RAMP LENGHT (s) = 9 km

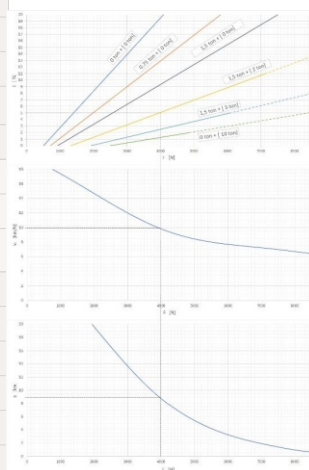

As per VDI guidelines 2198, this datasheet applies to standard electric tractor / platform truck only. Dimensions are not binding and can be changed in any moment. The performances must be intended for brand new machines, after having completed the running-in tested in San Donato Milanese Factory in normal climatic conditions. Performances and weight are to be intended with standard motors and battery (reported in bold) and with pneumatic tires. Some data can vary according to different equipments.

# CESAB Simai

## Electric platform truck PE20.1

Load Capacity 2000 kg

Towing Capacity 10000 kg



4-wheel platform truck, man on board, with rear-wheel drive. Extremely compact and easy to drive, ideal for all duties - both indoors and outdoors, even on long distances. The platform of the PE20 truck can be completed with other equipment.

- **Central chassis.**
- Phenol-resin bonded plywood **platform** size 2,000x1,300 mm - other sizes and materials available upon request. Aluminium tipping side walls h 300 mm available upon request.
- **Suspensions:** rubberised steel coil springs in the front, semi-elliptical leaf springs in the rear.
- **Drum service brake** acting on 4 wheels with twofold braking system. Electromagnetic and mechanical lever-type parking brake. Preset electrical **braking**, operating automatically when accelerator pedal is released, with first stroke of brake pedal and on reversing direction.
- Standard hydraulic **steering**.
- **2 operators on board.** Optimised driving position for maximum comfort and efficiency, low step-on platform for comfortable access as well as user-friendly and ergonomic dashboard.
- **"Man on board" device** with seat occupancy sensor. Available in basic version, with weather protection roof with front windscreen and electric wipers. PVC canvas doors or cab with hinged side doors available.

- **Lighting system:** 2 front lights (position/dipped-beam/main-beam), 2 front turn indicators, 2 rear turn indicators, 2 rear lights (position/brake lights). Horn. Flashing light, reversing light and blue lights available upon request.
- **Digital dashboard** with battery charge indicator, fault detection, speedometer and hour meter. 24 V DC/DC converter for auxiliary services.
- **Induction motor** equipped with encoder, thermal probes and negative electromagnetic parking brake with manual brake disengage lever.
- **Electronic speed control of AC motor** with energy recovery during deceleration and braking. Available also with towing hitch upon request.
- **Battery DIN 43531 A – available capacity 48V/480Ah.** Standard paint finish: Chassis dark grey RAL 7021, Body light grey RAL 7035. Other colours available on request.

All parts are easy to access for fast and effective maintenance. Lower costs due to AC technology and modular design.

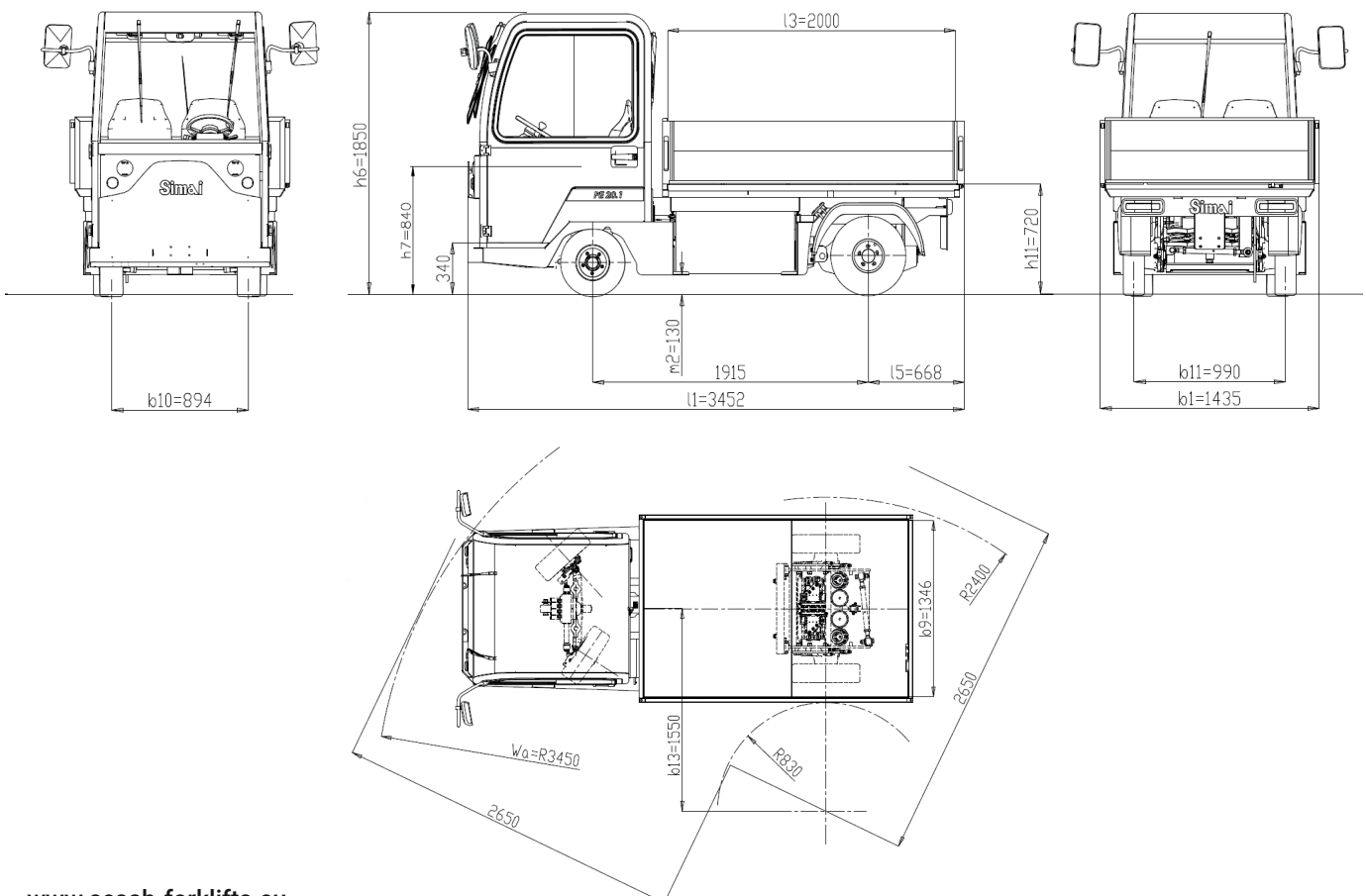

FEATURES	1.1	Manufacturer			SIMAI S.p.A.
	1.2	Model			PE20.1
	1.3	Drive			electric
	1.4	Operator Type			Sitting driver
	1.5	Load Capacity	Q	t	2
	1.5.1	Towing Capacity	Q	t	10
	1.7	Rated Drawbar pull	F	N	2200
WEIGHT	1.9	Wheelbase	Y	mm	1915
	2.1	Service weight (w/battery)		Kg	2200
	2.2	Axle loading laden front/rear (with operator 80 kg. each)		Kg	1710 / 2650
TIRES, CHASSIS	2.3	Axle loading unladen front/rear		Kg	1200 / 1000
	3.1	Tyres:Cushion(Cu),Superelastic(SE), Pneus(Pn) Poliurethane (PE)			SE/Pn
	3.2	Tyre size front			6.00-9
	3.3	Tyre size rear			6.00-9
	3.5	Wheels nr. Front/Rear (X=motive)			2/2X
	3.6	Tread front	$b_{10}$	mm	894
	3.7	Tread rear	$b_{11}$	mm	990
	4.7	Height of roof/cabin	$h_6$	mm	1850
	4.8	Seat height	$h_7$	mm	840
	DIMENSIONS	4.8.1	Step on platform height		mm
4.12		Coupling height	$h_{10}$	mm	355
4.13		Loading height	$h_{11}$	mm	720
4.16		Platform length	$l_3$	mm	2000
4.17		Rear overhang	$l_5$	mm	668
4.18		Platform width	$b_9$	mm	1346
4.19		Overall length	$l_1$	mm	3452
4.21		Overall width	$b_1$	mm	1435
4.32		Ground clearance - centre of wheelbase	$m_2$	mm	130
4.35		Turning radius front	$Wa$	mm	3450
4.35.1		Turning radius rear		mm	2400
4.36		Turning radius inner	$b_{13}$	mm	1550
4.36.1		Aisle width when turning 90°		mm	2650
PERFORMANCES		5.1	Travel speed laden/unladen		Km/h
	5.5	Drawbar pull laden		N	---
	5.5.1	Drawbar pull unladen		N	---
	5.6	Max. Drawbar pull		N	8000
	5.7	Gradeability laden/unladen		%	See chart
	5.8	Max. Gradeability laden/unladen		%	See chart
	5.10	Service / Parking brake (I=Hydraulic E=Electromagn. M=Mechanical)			I / E
MOTOR	5.10.1	Type of service brake front/rear			Drum / Wet disks
	6.1	Drive motor rating S2=60 min		kW	2 x 6,6
	6.1.1	Hydrauling steering motor rating S2=60 min		kW	---
	6.3	Battery according to DIN 43531 / 35 / 36 A, B, C, no			43531 A
	6.4	Battery voltage	U	V	48
	6.4.1	Battery rated capacity	$K_s$	Ah	480
	6.5	Battery weight		Kg	756-760
OTHER DATA	6.6	Energy consumption (VDI cycle)		kWh/h	-
	8.1	Drive Control			inverter A/C
	8.4	Sound level at driver's ear according to DIN 12053		dB(A)	69
	8.5	Towing coupling, type DIN			-

### READING EXAMPLE

#### LOADING CAPACITY + TRAILED

LOAD = 2 ton + [2 ton]

GRADIENT (i) = 4 %

DRAWBALL PULL (F) = 4000 N

SPEED (V0) = 10 [Km/h]

MAX PRACTICABLE RAMP LENGHT (s) = 7,5 km

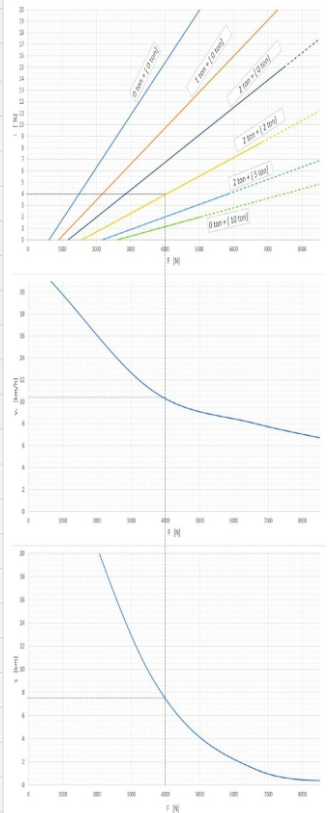

As per VDI guidelines 2198, this datasheet applies to standard electric tractor / platform truck only.

Dimensions are not binding and can be changed in any moment. The performances must be intended for brand new machines, after having completed the running-in tested in San Donato Milanese Factory in normal climatic conditions. Performances and weight are to be intended with standard motors and battery (reported in bold) and with pneumatic tires. Some data can vary according to different equipments.

# CESAB Simai

## Electric platform truck PE30

Load Capacity 3000 kg  
Towing Capacity 8000 kg



4-wheel platform truck, man on board, with rear-wheel drive. Extremely easy to drive, ideal for all duties - both indoors and outdoors, even on long distances. The platform of the PE30 truck can be completed with other equipment.

- **Central chassis.**
- Phenol-resin bonded plywood **platform** size 2,450x1500 mm - other sizes and materials available upon request. Aluminium tipping side walls h 400 mm available upon request.
- **Suspensions:** rubberised steel coil springs, stabiliser bar and shock absorbers in the front, semi-elliptical leaf springs in the rear.
- **Drum service brake** acting on 4 wheels - with twofold braking system. Front disk brakes and rear oil-bath multiple-disk brakes. Mechanical lever-type parking brake - negative hydraulic brake available upon request. Preset electrical **braking**, operating automatically when accelerator pedal is released, with first stroke of brake pedal and on reversing direction.
- Standard hydraulic **steering**.
- **2 operators on board.** Driving position in the front ensures excellent rear and front visibility. Suspension seats. Easy access to driving position thanks to low step-on platform.

- **“Man on board” device** with seat occupancy sensor. Available with weather protection roof with front and rear windscreen and electric wipers. PVC canvas doors or cab with hinged side doors available.
- **Lighting system:** 2 front lights (position/dipped-beam/main-beam), 2 front turn indicators, 2 rear turn indicators, 2 rear lights (position/brake lights), 2 reversing lights. Flashing light and blue lights available upon request.
- **Digital dashboard** with battery charge indicator, fault detection, speedometer and hour meter 24 V DC/DC converter for auxiliary services.
- **Induction motor.**
- **Electronic speed control of AC motor** with energy recovery during deceleration and braking. Available also with towing hitch upon request.
- **Battery 80 V** – available capacity 400Ah and 480Ah. Fast replacement from the side. Standard paint finish: chassis dark grey RAL 7021/body light grey RAL 7035. Other colours available upon request.

All parts are easy to access for fast and effective maintenance. Lower costs due to AC technology and modular design.

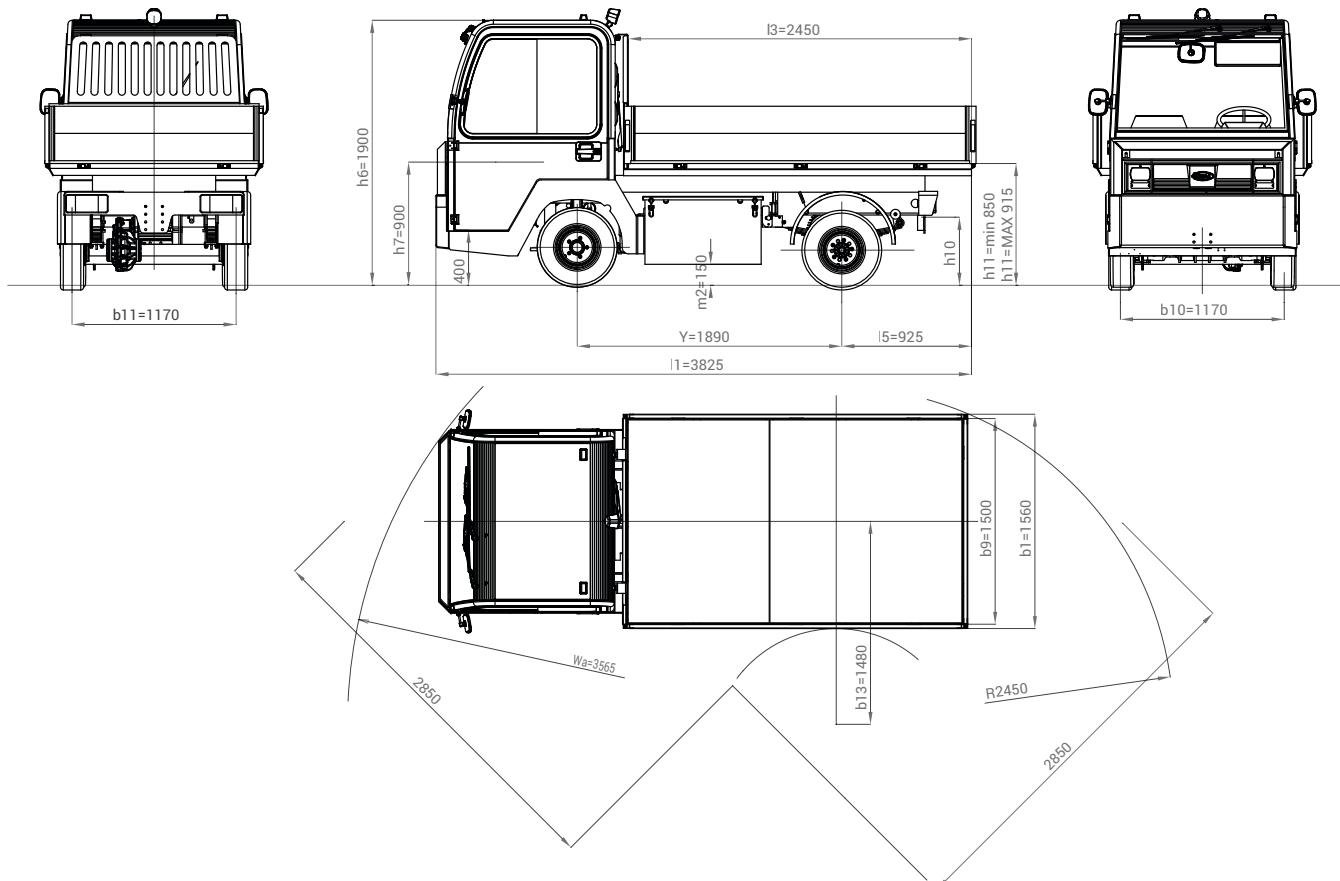

FEATURES	1.1	Manufacturer			SIMAI S.p.A.	
	1.2	Model			PE30	
	1.3	Drive			electric	
	1.4	Operator Type			Sitting driver	
	1.5	Load Capacity	Q	t	3	
	1.5.1	Towing Capacity	Q	t	8	
	1.7	Rated Drawbar pull	F	N	2400	
	1.9	Wheelbase	Y	mm	1890	
	WEIGHT	2.1	Service weight (w/battery)		Kg	2750
2.2		Axle loading laden front/rear (with operator 80 kg. each)		Kg	2300 / 3610	
2.3		Axle loading unladen front/rear		Kg	1500 / 1250	
TIRES, CHASSIS	3.1	Tyres:Cushion(Cu),Superelastic(SE), Pneus(Pn) Poliurethane (PE)			SE/Pn	
	3.2	Tyre size front			6.50-10	
	3.3	Tyre size rear			6.50-10	
	3.5	Wheels nr. Front/Rear (X=motive)			2 / 2X	
	3.6	Tread front	b <sub>10</sub>	mm	1170	
	3.7	Tread rear	b <sub>11</sub>	mm	1170	
	DIMENSIONS	4.7	Height of roof/cabin	h <sub>6</sub>	mm	1900
4.8		Seat height	h <sub>7</sub>	mm	900	
4.8.1		Step on platform height		mm	400	
4.12		Coupling height	h <sub>10</sub>	mm	425 - 480 - 535	
4.13		Loading height (min / MAX)	h <sub>11</sub>	mm	850 / 915	
4.16		Platform length	l <sub>3</sub>	mm	2450	
4.17		Rear overhang	l <sub>5</sub>	mm	925	
4.18		Platform width	b <sub>9</sub>	mm	1500	
4.19		Overall length	l <sub>1</sub>	mm	3825	
4.21		Overall width	b <sub>1</sub>	mm	1560	
4.32		Ground clearance - centre of wheelbase	m <sub>2</sub>	mm	150	
4.35		Turning radius front	Wa	mm	3565	
4.35.1		Turning radius rear		mm	2450	
4.36		Turning radius inner	b <sub>13</sub>	mm	1480	
4.36.1		Aisle width when turning 90°		mm	2850	
PERFORMANCES		5.1	Travel speed laden/unladen		Km/h	19 / 25
	5.5	Drawbar pull laden		N	1500	
	5.5.1	Drawbar pull unladen		N	2400	
	5.6	Max. Drawbar pull laden/unladen		N	- / 9500	
	5.7	Gradeability laden/unladen		%	See chart	
	5.8	Max. Gradeability laden/unladen		%	See chart	
	5.10	Service / Parking brake (I=Hydraulic E=Electromagn. M=Mechanical)			I / M	
	5.10.1	Type of service brake front/rear			Disk / drum	
	MOTOR	6.1	Drive motor rating S2=60 min		kW	12
		6.1.1	Hydrauling steering motor rating S2=60 min		kW	1 (Ac)
6.3		Battery according to DIN 43531 / 35 / 36 A, B, C, no			no	
6.4		Battery voltage	U	V	80	
6.4.1		Battery rated capacity	K <sub>5</sub>	Ah	350 - 400 - 480	
6.5		Battery weighth		Kg	1080 - 1120 - 1250	
6.6		Energy consumption (VDI cycle)		kWh/h	-	
OTHER DATA	8.1	Drive Control			inverter AC	
	8.4	Sound level at driver's ear according to DIN 12053		dB(A)	69	
	8.5	Towing coupling, type DIN			-	

READING EXAMPLE:  
 CHARGE = 1 TONS  
 GRADIENT = 13 %  
 DRAWBAR PULL = 6200 N  
 SPEED = 7,6 Km/h  
 MAX PRACTICABLE RAMP LENGTH = 1000 m

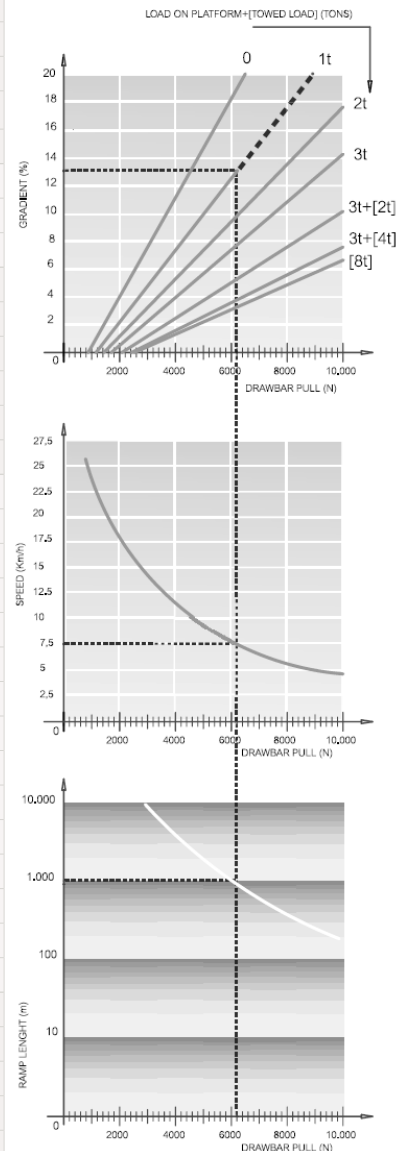

As per VDI guidelines 2198, this datasheet applies to standard electric tractor / platform truck only. Dimensions are not binding and can be changed in any moment. The performances must be intended for brand new machines, after having completed the running-in tested in San Donato Milanese Factory in normal climatic conditions. Performances and weight are to be intended with standard motors and battery (reported in bold) and with pneumatic tires. Some data can vary according to different equipments.

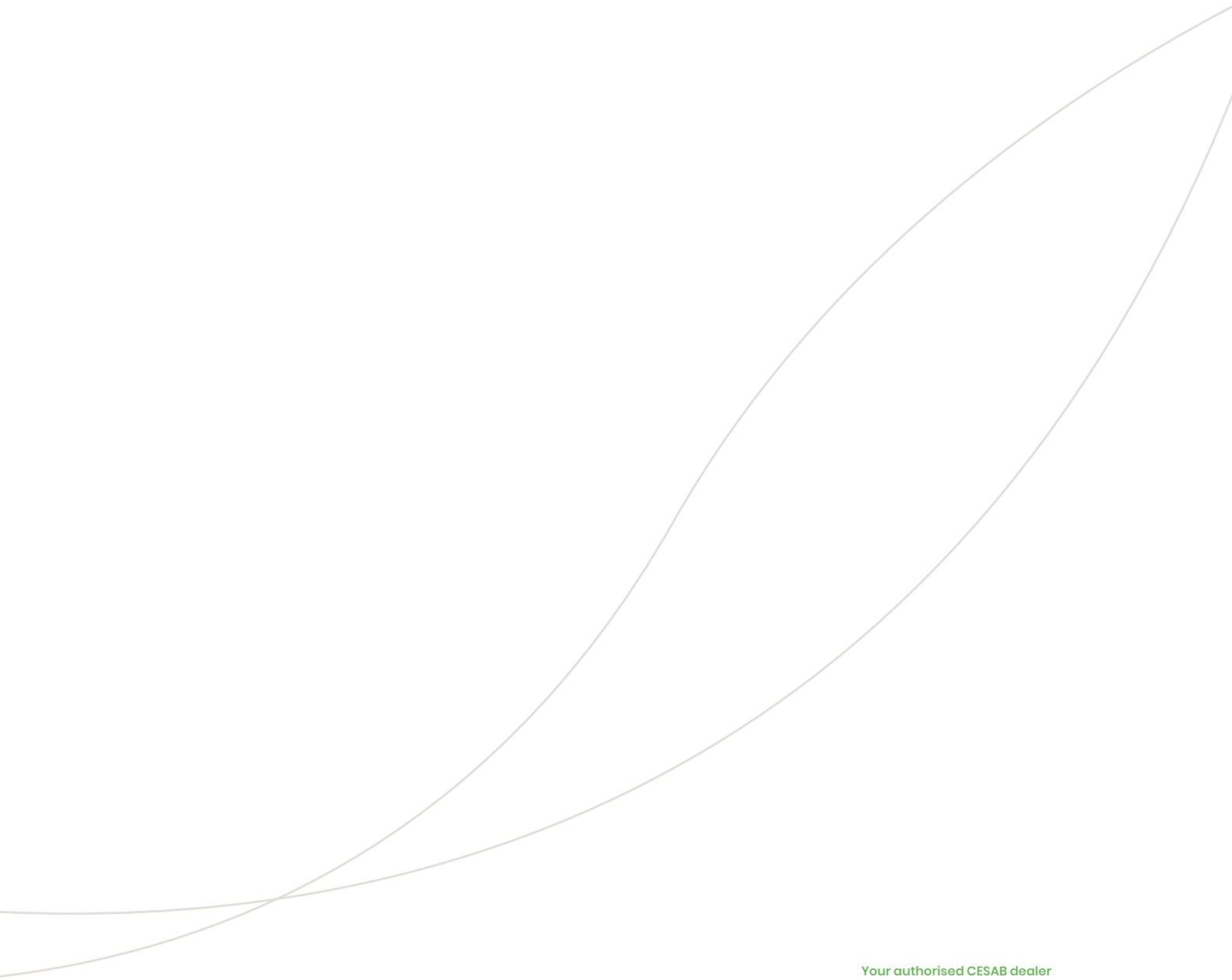

Your authorised CESAB dealer

Die Abbildungen zeigen möglicherweise in der Standardausführung des Fahrzeugs nicht enthaltene Sonderausstattung oder Zubehörteile.

Die Daten in dieser Broschüre wurden basierend auf unseren Standard-Testbedingungen ermittelt. Die Betriebsleistung kann je nach Spezifikation und Bedingung des Gabelstaplers sowie je nach Art und Zustand des Betriebsbereichs variieren.

Verfügbarkeit und Spezifikationen werden regional festgelegt. Änderungen bleiben ohne Vorankündigung vorbehalten. Für nähere Informationen wenden Sie sich bitte an Ihren autorisierten CESAB Vertragshändler. SIMAI\_FullRange\_EN\_10/2022 / TdH 04 – Copyright CESAB Material Handling Europe.