



CESAB

spec sheet

CESAB R300

1.4 - 2.5 tonne

Reach Trucks

Publication: 2021



CESAB R314 – R316

Truck Specifications (2021 Model)

CHARACTERISTICS					
1.1	Manufacturer		CESAB	CESAB	
1.2	Model		R314-2	R316-2	
1.3	Drive		Electric	Electric	
1.4	Operator type		Seated	Seated	
1.5	Load capacity/rated load	Q	[kg]	1400	1600
1.6	Load centre	c	[mm]	600	600
1.8	Load distance, centre of support arm wheel to face of forks	x	[mm]	310*	394*
1.9	Wheelbase	y	[mm]	1311	1395
WEIGHT					
2.1	Service weight including battery		[kg]	3390	3398
2.3	Axle load, mast retracted without load, drive/support arm wheel		[kg]	2067/1323	2123/1274
2.4	Axle load, mast extended with load, drive/support arm wheel		[kg]	667/4123	607/4390
2.5	Axle load, mast retracted with load, drive/support arm wheel		[kg]	1758/3032	1887/3110
WHEELS					
3.1	Drive/support arm wheel		[mm]	Polyurethane	Polyurethane
3.2	Wheel size, front		[mm]	Ø 343x140	Ø 343x140
3.3	Wheel size, rear		[mm]	Ø 300x106	Ø 300x106
3.5	Wheels, number front/rear (x=driven wheels)			1x/2	1x/2
3.7	Track width, rear	b11	[mm]	1134	1134
DIMENSIONS					
4.1	Tilt of fork, forward/backward	α/β	[deg]	-2°/4°*	-2°/4°*
4.2	Height, mast lowered	h_1	[mm]	2887*	2887*
4.3	Free lift	h_2	[mm]	2403*	2403*
4.4	Lift	h_3	[mm]	6945*	6945*
	Lift height	h_{23}	[mm]	7000*	7000*
4.5	Height, mast extended	h_4	[mm]	7540*	7540*
4.7	Height of overhead guard (cab)	h_6	[mm]	2198	2198
4.8	Seat height	h_7	[mm]	1136	1136
4.10	Height of support arms	h_8	[mm]	268	268
4.15	Height of lowered forks	h_{13}	[mm]	55	55
4.19	Overall length	l_1	[mm]	2413	2413
4.20	Length to face of forks	l_2	[mm]	1263	1263
4.21	Overall width	b_1	[mm]	1270	1270
4.22	Fork dimensions	s/e/l	[mm]	40/100/1150*	40/100/1150*
4.23	Fork carriage ISO 2328, class/type A, B			II A	II A
4.24	Fork carriage width	b_3	[mm]	819	819
4.25	Width over forks	b_5	[mm]	252-698	252-698
4.26	Distance between support arms	b_4	[mm]	900*	900*
4.28	Reach distance	l_4	[mm]	506*	590*
4.31	Ground clearance, with load, below mast	m_1	[mm]	68	68
4.32	Ground clearance, centre of wheelbase ²⁾	m_2	[mm]	74	74
4.33	Aisle width for pallets 1000 x 1200 crossways	A_{st}	[mm]	2687	2710
4.34	Aisle width for pallets 800 x 1200 lengthways	A_{st}	[mm]	2749	2757
4.35	Turning radius	W_o	[mm]	1573	1657
4.37	Length across support arms	l_7	[mm]	1744	1828
PERFORMANCE DATA					
5.1	Travel speed, with/without load		[km/h]	10,3/11 ¹⁾	10/11 ¹⁾
5.2	Lift speed, with/without load		[m/s]	0,38/0,68	0,36/0,68
	Lift speed, with/without load (High speed version)		[m/s]	0,57/0,92 ⁴⁾	0,52/0,92 ⁵⁾
5.3	Lowering speed, with/without load		[m/s]	0,59/0,55	0,59/0,55
5.4	Reach speed, with/without load		[m/s]	0,20/0,28	0,20/0,28
5.8	Max. gradeability, with/without load ³⁾		[%]	10/15	10/15
5.9	Acceleration time with/without load (over 10 m)		[s]	5,4/4,9	5,5/4,9
5.10	Service brake			Electric	Electric
ELECTRIC MOTOR					
6.1	Drive motor rating S2 60 min		[kW]	9,0	9,0
6.2	Lift motor rating S3 15%		[kW]	11,0	11,0
	Lift motor rating S3 15% (High speed version)		[kW]	15,0	15,0
6.4	Battery voltage, nominal capacity K_s		[V/Ah]	48/465*	48/465*
6.5	Battery weight		[kg]	685*	685*
6.6	Energy consumption acc to EN16796		[kWh/h]	2,9	3,1
6.7	Turnover output		[t/h]	56	66
6.8	Energy consumption at turnover output		[kWh/h]	3,2	3,3
OTHERS					
8.1	Type of drive control			Variable AC	Variable AC
8.2	Sound level at the driver's ear according to EN 12 053		[dB(A)]	64	64

¹⁾ 11/11 km/h with support wheel brakes ²⁾ 15 mm under studs ³⁾ Measured according to company standard ⁴⁾ With Li-ion battery 0.64/0.92

⁵⁾ With Li-ion battery 0.60/0.92 ³⁾ Other alternatives are available

All data are based on table configuration. Other configurations may give other values. Truck performance and dimensions are nominal and subject to tolerances. Products and specifications are subject to change without notice.

CESAB R318 – R325

Truck Specifications (2021 Model)

CHARACTERISTICS						
1.1	Manufacturer		CESAB	CESAB	CESAB	
1.2	Model		R318-2	R320-2	R325-2	
1.3	Drive		Electric	Electric	Electric	
1.4	Operator type		Seated	Seated	Seated	
1.5	Load capacity/rated load	Q	[kg]	1800	2000	2500
1.6	Load centre	c	[mm]	600	600	600
1.8	Load distance, centre of support arm wheel to face of forks	x	[mm]	373*	433*	388*
1.9	Wheelbase	y	[mm]	1455	1515	1575
WEIGHT						
2.1	Service weight including battery		[kg]	3908	4091	4614
2.3	Axle load, mast retracted without load, drive/support arm wheel		[kg]	2357/1551	2510/1581	2702/1912
2.4	Axle load, mast extended with load, drive/support arm wheel		[kg]	717/4991	764/5327	721/6392
2.5	Axle load, mast retracted with load, drive/support arm wheel		[kg]	2054/3655	2266/3825	2339/4775
WHEELS						
3.1	Drive/support arm wheel		[mm]	Polyurethane	Polyurethane	Polyurethane
3.2	Wheel size, front		[mm]	Ø 360x160	Ø 360x160	Ø 360x160
3.3	Wheel size, rear		[mm]	Ø 350x106	Ø 350x106	Ø 350x106
3.5	Wheels, number front/rear (x=driven wheels)			1x/2	1x/2	1x/2
3.7	Track width, rear	b11	[mm]	1134	1134	1134
DIMENSIONS						
4.1	Tilt of fork, forward/backward	α/β	[deg]	-2°/4°*	-2°/4°*	-2°/4°*
4.2	Height, mast lowered	h_1	[mm]	2966*	2966*	2936*
4.3	Free lift	h_2	[mm]	2459*	2459*	2449*
4.4	Lift	h_3	[mm]	6945*	6945*	6945*
	Lift height	h_{23}	[mm]	7000*	7000*	7000*
4.5	Height, mast extended	h_4	[mm]	7548*	7548*	7545*
4.7	Height of overhead guard (cab)	h_6	[mm]	2261	2261	2261
4.8	Seat height	h_7	[mm]	1198	1198	1198
4.10	Height of support arms	h_8	[mm]	330	330	330
4.15	Height of lowered forks	h_{13}	[mm]	55	55	55
4.19	Overall length	l_1	[mm]	2494	2494	2599
4.20	Length to face of forks	l_2	[mm]	1344	1344	1449
4.21	Overall width	b_1	[mm]	1270	1270	1270
4.22	Fork dimensions	s/e/l	[mm]	40/120/1150*	40/120/1150*	45/125/1150*
4.23	Fork carriage ISO 2328, class/type A, B			II A	II A	II A
4.24	Fork carriage width	b_3	[mm]	819	819	819
4.25	Width over forks	b_5	[mm]	272-718	272-718	277-723
4.26	Distance between support arms	b_4	[mm]	900*	900*	900*
4.28	Reach distance	l_4	[mm]	594*	654*	609*
4.31	Ground clearance, with load, below mast	m_1	[mm]	68	68	68
4.32	Ground clearance, centre of wheelbase ²⁾	m_2	[mm]	74	74	74
4.33	Aisle width for pallets 1000 x 1200 crossways	A_{st}	[mm]	2785	2802	2894
4.34	Aisle width for pallets 800 x 1200 lengthways	A_{st}	[mm]	2836	2842	2942
4.35	Turning radius	W_a	[mm]	1717	1777	1837
4.37	Length across support arms	l_7	[mm]	1913	1973	2033
PERFORMANCE DATA						
5.1	Travel speed, with/without load		[km/h]	11/11	11/11	11/11
5.2	Lift speed, with/without load		[m/s]
	Lift speed, with/without load (High speed version)		[m/s]	0,46/0,68	0,43/0,68	0,37/0,64
5.3	Lowering speed, with/without load		[m/s]	0,60/0,55	0,60/0,55	0,58/0,53
5.4	Reach speed, with/without load		[m/s]	0,20/0,28	0,20/0,28	0,20/0,28
5.8	Max. gradeability, with/without load ²⁾		[%]	10/15	10/15	7/12
5.9	Acceleration time with/without load (over 10 m)		[s]	4,9/4,4	5,0/4,5	5,4/4,7
5.10	Service brake			Electric	Electric	Electric
ELECTRIC MOTOR						
6.1	Drive motor rating S2 60 min		[kW]	10.5	10.5	10.5
6.2	Lift motor rating S3 15%		[kW]
	Lift motor rating S3 15% (High speed version)		[kW]	15.0	15.0	15.0
6.4	Battery voltage, nominal capacity K_s		[V/Ah]	48/620*	48/620*	48/775*
6.5	Battery weight		[kg]	875*	875*	1055*
6.6	Energy consumption acc to EN16796		[kWh/h]	3,3	3,9	4,4
6.7	Turnover output		[t/h]	76	84	105
6.8	Energy consumption at turnover output		[kWh/h]	3,7	4,2	4,7
OTHERS						
8.1	Type of drive control			Variable AC	Variable AC	Variable AC
8.2	Sound level at the driver's ear according to EN 12 053		[dB(A)]	65	65	62

¹⁾ 15 mm under studs ²⁾ Measured according to company standard ³⁾ Other alternatives are available

All data are based on table configuration. Other configurations may give other values. Truck performance and dimensions are nominal and subject to tolerances. Products and specifications are subject to change without notice.

1.4 - 2.5 tonne

CESAB R314 - R325

Dimensional Drawings (2021 Model)

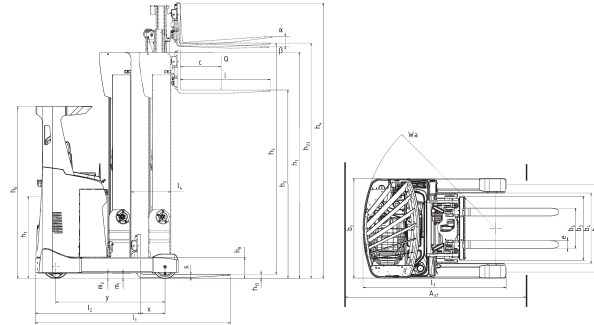

Battery compartments

DIMENSIONS			R314			R316		
Battery compartment depth	[mm]		275	347	419	275	347	419
1.8 Load distance, centre of support arm wheel to face of forks	x [mm]		310 ¹⁾	238 ¹⁾	157	394 ¹⁾	322 ¹⁾	250 ¹⁾
4.20 Length to face of forks	l ₂ [mm]		1263 ²⁾	1335 ²⁾	1416	1263 ²⁾	1335 ²⁾	1407 ²⁾
4.33 Aisle width for pallets 1000x1200 crossways	A ₃₃ [mm]		2687	2743	2808	2710	2762	2817
4.34 Aisle width for pallets 800x1200 lengthways	A ₃₄ [mm]		2749	2815	2890	2757	2822	2888
4.35 Turning Radius	W ₀ [mm]		1573	1573	1573	1657	1657	1657
6.4 Battery voltage, nominal capacity K ₅ Lead-acid	[V/Ah]		48/465	48/620	48/775	48/465	48/620	48/775
Battery voltage, nominal capacity K ₅ Li-ion	[V/Ah]		...	48/300-420	48/300-630	...	48/300-420	48/300-630
6.5 Battery weight, min.-max.	[kg]		685-825	875-1030	1055-1235	685-825	875-1030	1055-1235

¹⁾ With battery in sleigh - 9 mm ²⁾ With battery in sleigh + 9 mm

DIMENSIONS	CESAB R318						CESAB R320						CESAB R325			
	TRIPLEX FULL FREELIFT - B		TRIPLEX FULL FREELIFT - C		TRIPLEX FULL FREELIFT - B		TRIPLEX FULL FREELIFT - C		TRIPLEX FULL FREELIFT - D		TRIPLEX FULL FREELIFT - C		TRIPLEX FULL FREELIFT - D			
Battery compartment depth	347	419	491	347	419	491	347	419	491	347	419	491	419	491	419	491
1.8 Load distance, centre of support arm wheel to face of forks	x [mm]	373	301	229	340	268	196	433	361	289	400	328	256	345	273	201
4.20 Length to face of forks	l ₂ [mm]	1344	1416	1488	1377	1449	1521	1344	1416	1488	1377	1449	1521	1432	1504	1576
4.33 Aisle width for pallets 1000x1200 crossways	A ₃₃ [mm]	2785	2838	2894	2809	2863	2920	2802	2853	2907	2825	2878	2933	2885	2920	2976
4.34 Aisle width for pallets 800x1200 lengthways	A ₃₄ [mm]	2836	2901	2967	2865	2931	2998	2842	2906	2972	2871	2936	3002	2921	2987	3053
4.35 Turning Radius	W ₀ [mm]	1717	1717	1717	1717	1717	1717	1777	1777	1777	1777	1777	1777	1777	1777	1777
6.4 Battery voltage, nominal capacity K ₅ Lead-acid	[V/Ah]	620	775	930	620	775	930	620	775	930	620	775	930	620	775	930
Battery voltage, nominal capacity K ₅ Li-ion	[V/Ah]	300-420	300-630	300-630	300-420	300-630	300-630	300-420	300-630	300-630	300-420	300-630	300-630	300-420	300-630	300-630
6.5 Battery weight, min.-max.	[kg]	875-1030	1055-1235	1250-1440	875-1030	1055-1235	1250-1440	875-1030	1055-1235	1250-1440	875-1030	1055-1235	1250-1440	875-1030	1055-1235	1250-1440

Mast Dimensions

CESAB R314/316		TRIPLEX FULL FREELIFT A														
Lift height	h ₃ [mm]	4900	5400	5700	6300	7000	7250	7500	8000	8500	9000	9500	10000	10250	10500	11000
4.4 Lift	h ₂₃ [mm]	4845	5345	5645	6245	6945	7195	7445	7945	8445	8945	9445	9945	10195	10445	10945
4.2 Height, mast lowered	h ₁ [mm]	2187	2354	2454	2654	2887	2971	3054	3221	3387	3554	3721	3887	3971	4054	4221
4.3 Free lift	h ₂ [mm]	1703	1871	1971	2171	2403	2487	2571	2737	2903	3071	3237	3403	3487	3571	3737
4.5 Height, mast extended	h ₄ [mm]	5440	5941	6241	6841	7540	7792	8041	8542	9040	9541	10042	10540	10791	11041	11542

CESAB R318		TRIPLEX FULL FREELIFT B										TRIPLEX FULL FREELIFT C						
Lift height	h ₃ [mm]	4850	5400	5700	6300	7000	7500	8000	8500	9000	9500	10000	10500	11000	11500	12000	12500	13000
4.4 Lift	h ₂₃ [mm]	4795	5345	5645	6245	6945	7445	7945	8445	8945	9445	9945	10445	10945	11445	11945	12445	12945
4.2 Height, mast lowered	h ₁ [mm]	2249	2432	2532	2732	2966	3132	3299	3466	3632	3799	3966	4132	4299	4463	4630	4797	4963
4.3 Free lift	h ₂ [mm]	1741	1925	2025	2225	2459	2625	2791	2959	3125	3291	3459	3625	3791	3949	4117	4283	4449
4.5 Height, mast extended	h ₄ [mm]	5397	5946	6246	6846	7548	8046	8547	9048	9546	10047	10548	11046	11547	12045	12546	13047	13545

CESAB R320		TRIPLEX FULL FREELIFT B								TRIPLEX FULL FREELIFT C				TRIPLEX FULL FREELIFT D				
Lift height	h ₃ [mm]	4850	5400	5700	6300	7000	7500	8000	8500	9000	9500	10000	10500	11000	11500	12000	12500	13000
4.4 Lift	h ₂₃ [mm]	4795	5345	5645	6245	6945	7445	7945	8445	8945	9445	9945	10445	10945	11445	11945	12445	12945
4.2 Height, mast lowered	h ₁ [mm]	2249	2432	2532	2732	2966	3132	3299	3466	3632	3799	3963	4130	4297	4463	4630	4797	4963
4.3 Free lift	h ₂ [mm]	1741	1925	2025	2225	2459	2625	2791	2959	3125	3291	3449	3617	3783	3949	4117	4283	4449
4.5 Height, mast extended	h ₄ [mm]	5397	5946	6246	6846	7548	8046	8547	9048	9546	10047	10545	11046	11547	12045	12546	13047	13545

CESAB R325		TRIPLEX FULL FREELIFT C								TRIPLEX FULL FREELIFT D								
Lift height	h ₃ [mm]	4850	5400	5700	6300	7000	7500	8000	8500	9000	9500	10000	10500	11000	11500	12000	12500	13000
4.4 Lift	h ₂₃ [mm]	4795	5345	5645	6245	6945	7445	7945	8445	8945	9445	9945	10445	10945	11445	11945	12445	12945
4.2 Height, mast lowered	h ₁ [mm]	2247	2430	2530	2730	2936	3130	3297	3463	3630	3797	3963	4130	4297	4463	4630	4797	4963
4.3 Free lift	h ₂ [mm]	1733	1917	2017	2217	2449	2617	2783	2949	3117	3283	3449	3617	3783	3949	4117	4283	4449
4.5 Height, mast extended	h ₄ [mm]	5397	5946	6246	6846	7545	8046	8547	9045	9546	10047	10545	11046	11547	12045	12546	13047	13545

CESAB R314 – R316

Truck Specifications with Cold Store Cabin (2022 Model)

CHARACTERISTICS					
1.1	Manufacturer		CESAB	CESAB	
1.2	Model		R314	R316	
1.3	Drive		Electric	Electric	
1.4	Operator type		Seated	Seated	
1.5	Load capacity/rated load	Q	[kg]	1400	1600
1.6	Load centre	c	[mm]	600	600
1.8	Load distance, centre of support arm wheel to face of forks	x	[mm]	238*	322*
1.9	Wheelbase	y	[mm]	1311	1395
WEIGHT					
2.1	Service weight including battery		[kg]	3760	3767
2.3	Axle load, mast retracted without load, drive/support arm wheel		[kg]	2289/1471	2353/1414
2.4	Axle load, mast extended with load, drive/support arm wheel		[kg]	967/4193	911/4456
2.5	Axle load, mast retracted with load, drive/support arm wheel		[kg]	1902/3257	2035/3333
WHEELS					
3.1	Drive/support arm wheel		[mm]	Polyurethane	Polyurethane
3.2	Wheel size, front		[mm]	ø 343x140	ø 343x140
3.3	Wheel size, rear		[mm]	ø 300x106	ø 300x106
3.5	Wheels, number front/rear (x=driven wheels)			1x/2	1x/2
3.7	Track width, rear	bll	[mm]	1134	1134
DIMENSIONS					
4.1	Tilt of fork, forward/backward	α/β	[deg]	-2°/4°*	-2°/4°*
4.2	Height, mast lowered	h_1	[mm]	2887*	2887*
4.3	Free lift	h_2	[mm]	2403*	2403*
4.4	Lift	h_3	[mm]	6945*	6945*
	Lift height	h_{23}	[mm]	7000*	7000*
4.5	Height, mast extended	h_4	[mm]	7540*	7540*
4.7	Height of overhead guard (cab)	h_6	[mm]	2200	2200
4.8	Seat height	h_7	[mm]	1136	1136
4.10	Height of support arms	h_8	[mm]	268	268
4.15	Height of lowered forks	h_{13}	[mm]	55	55
4.19	Overall length	l_1	[mm]	2548	2548
4.20	Length to face of forks	l_2	[mm]	1398	1398
4.21	Overall width	b_1	[mm]	1270	1270
4.22	Fork dimensions	s/e/l	[mm]	40/100/1150*	40/100/1150*
4.23	Fork carriage ISO 2328, class/type A, B			II A	II A
4.24	Fork carriage width	b_3	[mm]	819	819
4.25	Width over forks	b_5	[mm]	252-698	252-698
4.26	Distance between support arms	b_4	[mm]	900*	900*
4.28	Reach distance	l_4	[mm]	434*	518*
4.31	Ground clearance, with load, below mast	m_1	[mm]	68	68
4.32	Ground clearance, centre of wheelbase ²⁾	m_2	[mm]	74	74
4.33	Aisle width for pallets 1000 x 1200 crossways	A_{st}	[mm]	2802	2825
4.34	Aisle width for pallets 800 x 1200 lengthways	A_{st}	[mm]	2877	2885
4.35	Turning radius	W_o	[mm]	1620	1720
4.37	Length across support arms	l_7	[mm]	1807	1891
PERFORMANCE DATA					
5.1	Travel speed, with/without load		[km/h]	10,3/11 ¹⁾	10/11 ¹⁾
5.2	Lift speed, with/without load		[m/s]	0,38/0,68	0,36/0,68
	Lift speed, with/without load (High speed version)		[m/s]	0,57/0,92	0,52/0,92
5.3	Lowering speed, with/without load		[m/s]	0,59/0,55	0,59/0,55
5.4	Reach speed, with/without load		[m/s]	0,20/0,28	0,20/0,28
5.8	Max. gradeability, with/without load ³⁾		[%]	10/15	10/15
5.10	Service brake			Electric	Electric
ELECTRIC MOTOR					
6.1	Drive motor rating S2 60 min		[kW]	7.5	7.5
6.2	Lift motor rating S3 15%		[kW]	11.0	11.0
	Lift motor rating S3 15% (High speed version)		[kW]	15.0	15.0
6.4	Battery voltage, nominal capacity K_5		[V/Ah]	48/620*	48/620*
6.5	Battery weight		[kg]	875*	875*
OTHERS					
8.1	Type of drive control			Variable AC	Variable AC

¹⁾ 11/11 km/h with support wheel brakes ²⁾ 15 mm under studs ³⁾ Measured according to company standard ¹⁾ Other alternatives are available
All data are based on table configuration. Other configurations may give other values. Truck performance and dimensions are nominal and subject to tolerances. Products and specifications are subject to change without notice.

CESAB R318 – R325

Truck Specifications with Cold store Cabin (2022 Model)

CHARACTERISTICS						
1.1	Manufacturer		CESAB	CESAB	CESAB	
1.2	Model		R318	R320	R325	
1.3	Drive		Electric	Electric	Electric	
1.4	Operator type		Seated	Seated	Seated	
1.5	Load capacity/rated load	Q	[kg]	1800	2000	2500
1.6	Load centre	c	[mm]	600	600	600
1.8	Load distance, centre of support arm wheel to face of forks	x	[mm]	373*	433*	388*
1.9	Wheelbase	y	[mm]	1455	1515	1575
WEIGHT						
2.1	Service weight including battery		[kg]	4033	4216	4738
2.3	Axle load, mast retracted without load, drive/support arm wheel		[kg]	2518/1515	2670/1546	2860/1879
2.4	Axle load, mast extended with load, drive/support arm wheel		[kg]	878/4955	924/5292	879/6359
2.5	Axle load, mast retracted with load, drive/support arm wheel		[kg]	2215/3618	2425/3791	2497/4741
WHEELS						
3.1	Drive/support arm wheel		[mm]	Polyurethane	Polyurethane	Polyurethane
3.2	Wheel size, front		[mm]	ø 360x160	ø 360x160	ø 360x160
3.3	Wheel size, rear		[mm]	ø 350x106	ø 350x106	ø 350x106
3.5	Wheels, number front/rear (x=driven wheels)			1x/2	1x/2	1x/2
3.7	Track width, rear	bll	[mm]	1134	1134	1134
DIMENSIONS						
4.1	Tilt of fork, forward/backward	α/β	[deg]	-2°/4°*	-2°/4°*	-2°/4°*
4.2	Height, mast lowered	h_1	[mm]	2966*	2966*	2936*
4.3	Free lift	h_2	[mm]	2459*	2459*	2449*
4.4	Lift	h_3	[mm]	6945*	6945*	6945*
	Lift height	h_{23}	[mm]	7000*	7000*	7000*
4.5	Height, mast extended	h_4	[mm]	7548*	7548*	7545*
4.7	Height of overhead guard (cab)	h_6	[mm]	2263	2263	2263
4.8	Seat height	h_7	[mm]	1198	1198	1198
4.10	Height of support arms	h_8	[mm]	330	330	330
4.15	Height of lowered forks	h_{13}	[mm]	55	55	55
4.19	Overall length	l_1	[mm]	2557	2557	2662
4.20	Length to face of forks	l_2	[mm]	1407	1407	1512
4.21	Overall width	b_1	[mm]	1270	1270	1270
4.22	Fork dimensions	s/e/l	[mm]	40/120/1150*	40/120/1150*	45/125/1150*
4.23	Fork carriage ISO 2328, class/type A, B			II A	II A	II A
4.24	Fork carriage width	b_3	[mm]	819	819	819
4.25	Width over forks	b_5	[mm]	272-718	272-718	277-723
4.26	Distance between support arms	b_4	[mm]	900*	900*	900*
4.28	Reach distance	l_4	[mm]	594*	654*	609*
4.31	Ground clearance, with load, below mast	m_1	[mm]	68	68	68
4.32	Ground clearance, centre of wheelbase ¹⁾	m_2	[mm]	74	74	74
4.33	Aisle width for pallets 1000 x 1200 crossways	A_{st}	[mm]	2848	2865	2957
4.34	Aisle width for pallets 800 x 1200 lengthways	A_{st}	[mm]	2899	2905	3005
4.35	Turning radius	W_o	[mm]	1780	1840	1900
4.37	Length across support arms	l_7	[mm]	1976	2036	2096
PERFORMANCE DATA						
5.1	Travel speed, with/without load		[km/h]	11/11	11/11	11/11
5.2	Lift speed, with/without load		[m/s]
	Lift speed, with/without load (High speed version)		[m/s]	0,46/0,68	0,43/0,68	0,37/0,64
5.3	Lowering speed, with/without load		[m/s]	0,60/0,55	0,60/0,55	0,58/0,53
5.4	Reach speed, with/without load		[m/s]	0,20/0,28	0,20/0,28	0,20/0,28
5.8	Max. gradeability, with/without load ²⁾		[%]	10/15	10/15	7/12
5.9	Acceleration time with/without load (over 10 m)		[s]	TBA	TBA	TBA
5.10	Service brake			Electric	Electric	Electric
ELECTRIC MOTOR						
6.1	Drive motor rating S2 60 min		[kW]	9	9	9
6.2	Lift motor rating S3 15%		[kW]
	Lift motor rating S3 15% (High speed version)		[kW]	15.0	15.0	15.0
6.4	Battery voltage, nominal capacity K_s		[V/Ah]	48/620*	48/620*	48/775*
6.5	Battery weight		[kg]	875*	875*	1055*
OTHERS						
8.1	Type of drive control			Variable AC	Variable AC	Variable AC

¹⁾ 15 mm under studs ²⁾ Measured according to company standard ³⁾ Other alternatives are available

All data are based on table configuration. Other configurations may give other values. Truck performance and dimensions are nominal and subject to tolerances. Products and specifications are subject to change without notice.

CESAB R314 - R325

Dimensional Drawings (2022 Model)

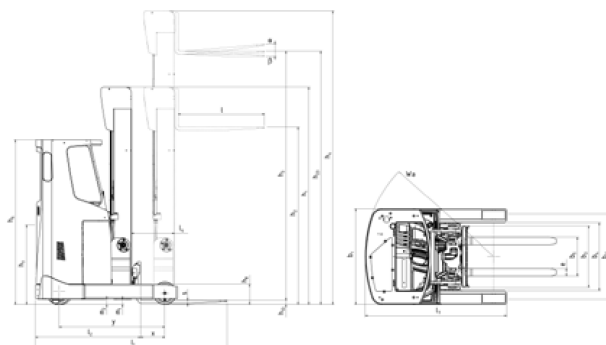

Battery compartments

DIMENSIONS			R314			R316			
Battery compartment depth		[mm]	275	347	419	275	347	419	491
1.8	Load distance, centre of support arm wheel to face of forks	x [mm]	310 ¹⁾	238 ¹⁾	157	394 ¹⁾	322 ¹⁾	250 ¹⁾	169
4.20	Length to face of forks	l ₂ [mm]	1263 ²⁾	1398 ²⁾	1479	1263 ²⁾	1398 ²⁾	1470 ²⁾	1551
4.33	Aisle width for pallets 1000x1200 crossways	A _{cr} [mm]	2687	2808	2873	2710	2825	2880	2945
4.34	Aisle width for pallets 800x1200 lengthways	A _{sl} [mm]	2749	2880	2955	2757	2885	2951	3026
4.35	Turning Radius	W _o [mm]	1573	1638	1638	1657	1720	1720	1720
6.4	Battery voltage, nominal capacity K _s lead-acid	[V/Ah]	48/465	48/620	48/775	48/465	48/620	48/775	48/930
	Battery voltage, nominal capacity K5 Li-ion (heated version through SDR)		---	48/300-420	48/300-630	---	48/300-420	48/300-630	48/300-630
6.5	Battery weight, min.—max.	[kg]	685-825	875-1030	1055-1235	685-825	875-1030	1055-1235	1250-1440

¹⁾ With battery in sleigh - 9 mm ²⁾ With battery in sleigh + 9 mm

DIMENSIONS	CESAB R318						CESAB R320						CESAB R325								
	TRIPLEX FULL FREELIFT - B		TRIPLEX FULL FREELIFT - C		TRIPLEX FULL FREELIFT - B		TRIPLEX FULL FREELIFT - C		TRIPLEX FULL FREELIFT - D		TRIPLEX FULL FREELIFT - C		TRIPLEX FULL FREELIFT - D								
Battery compartment depth	347	419	491	347	419	491	347	419	491	347	419	491	419	491	419	491					
1.8	Load distance, centre of support arm wheel to face of forks	x [mm]	373	301	229	340	268	196	433	361	289	400	328	256	345	273	201	388	316	333	261
4.20	Length to face of forks	l ₂ [mm]	1407	1479	1551	1440	1512	1584	1407	1479	1551	1440	1512	1584	1495	1567	1639	1512	1584	1567	1639
4.33	Aisle width for pallets 1000x1200 crossways	A _{cr} [mm]	2848	2901	2957	2872	2926	2983	2865	2916	2970	2888	2941	2996	2928	2983	3039	2957	3010	2997	3052
4.34	Aisle width for pallets 800x1200 lengthways	A _{sl} [mm]	2899	2964	3030	2928	2994	3061	2905	2969	3035	2934	2999	3065	2984	3050	3116	3005	3070	3055	3121
4.35	Turning Radius	W _o [mm]	1780	1780	1780	1780	1780	1780	1840	1840	1840	1840	1840	1840	1840	1840	1840	1900	1900	1900	1900
6.4	Battery voltage, nominal capacity K _s Lead-acid	[V/Ah]	620	775	930	620	775	930	620	775	930	620	775	930	620	775	930	775	930	775	930
	Battery voltage, nominal capacity K _s Li-ion	[Ah]	300-420	300-420	300-420	300-420	300-420	300-420	300-420	300-420	300-420	300-420	300-420	300-420	300-420	300-420	300-420	300-420	300-420	300-420	300-420
6.5	Battery weight, min.—max.	[kg]	875-1030	1055-1235	1250-1440	875-1030	1055-1235	1250-1440	875-1030	1055-1235	1250-1440	875-1030	1055-1235	1250-1440	875-1030	1055-1235	1250-1440	1055-1235	1250-1440	1055-1235	1250-1440

Mast Dimensions

CESAB R314/316		TRIPLEX FULL FREELIFT A															
Lift height	h ₃ [mm]	4900	5400	5700	6300	7000	7250	7500	8000	8500	9000	9500	10000	10250	10500	11000	
4.4	Lift	h ₂₃ [mm]	4845	5345	5645	6245	6945	7195	7445	7945	8445	8945	9445	9945	10195	10445	10945
4.2	Height, mast lowered	h ₁ [mm]	2187	2354	2454	2654	2887	2971	3054	3221	3387	3554	3721	3887	3971	4054	4221
4.3	Free lift	h ₂ [mm]	1703	1871	1971	2171	2403	2487	2571	2737	2903	3071	3237	3403	3487	3571	3737
4.5	Height, mast extended	h ₄ [mm]	5440	5941	6241	6841	7540	7792	8041	8542	9040	9541	10042	10540	10791	11041	11542

CESAB R318		TRIPLEX FULL FREELIFT B										TRIPLEX FULL FREELIFT C							
Lift height	h ₃ [mm]	4850	5400	5700	6300	7000	7500	8000	8500	9000	9500	10000	10500	11000	11500	12000	12500	13000	
4.4	Lift	h ₂₃ [mm]	4795	5345	5645	6245	6945	7445	7945	8445	8945	9445	9945	10445	10945	11445	11945	12445	12945
4.2	Height, mast lowered	h ₁ [mm]	2249	2432	2532	2732	2966	3132	3299	3466	3632	3799	3966	4132	4299	4463	4630	4797	4963
4.3	Free lift	h ₂ [mm]	1741	1925	2025	2225	2459	2625	2791	2959	3125	3291	3449	3625	3791	3949	4117	4283	4449
4.5	Height, mast extended	h ₄ [mm]	5397	5946	6246	6846	7548	8046	8547	9048	9546	10047	10548	11046	11547	12045	12546	13047	13545

CESAB R320		TRIPLEX FULL FREELIFT B									TRIPLEX FULL FREELIFT C			TRIPLEX FULL FREELIFT D					
Lift height	h ₃ [mm]	4850	5400	5700	6300	7000	7500	8000	8500	9000	9500	10000	10500	11000	11500	12000	12500	13000	
4.4	Lift	h ₂₃ [mm]	4795	5345	5645	6245	6945	7445	7945	8445	8945	9445	9945	10445	10945	11445	11945	12445	12945
4.2	Height, mast lowered	h ₁ [mm]	2249	2432	2532	2732	2966	3132	3299	3466	3632	3799	3963	4130	4297	4463	4630	4797	4963
4.3	Free lift	h ₂ [mm]	1741	1925	2025	2225	2459	2625	2791	2959	3125	3291	3449	3617	3783	3949	4117	4283	4449
4.5	Height, mast extended	h ₄ [mm]	5397	5946	6246	6846	7548	8046	8547	9048	9546	10047	10545	11046	11547	12045	12546	13047	13545

CESAB R325		TRIPLEX FULL FREELIFT C										TRIPLEX FULL FREELIFT D							
Lift height	h ₃ [mm]	4850	5400	5700	6300	7000	7500	8000	8500	9000	9500	10000	10500	11000	11500	12000	12500	13000	
4.4	Lift	h ₂₃ [mm]	4795	5345	5645	6245	6945	7445	7945	8445	8945	9445	9945	10445	10945	11445	11945	12445	12945
4.2	Height, mast lowered	h ₁ [mm]	2247	2430	2530	2730	2936	3130	3297	3463	3630	3797	3963	4130	4297	4463	4630	4797	4963
4.3	Free lift	h ₂ [mm]	1733	1917	2017	2217	2449	2617	2783	2949	3117	3283	3449	3617	3783	3949	4117	4283	4449
4.5	Height, mast extended	h ₄ [mm]	5397	5946	6246	6846	7545	8046	8547	9045	9546	10047	10545	11046	11547	12045	12546	13047	13545



www.cesab-forklifts.eu



Your authorised CESAB dealer



Pictures may show optional equipment and accessories not included in the standard execution of the truck.

The data in this specification sheet was determined based on our standard testing conditions. Operating performance may vary depending on the actual specification and condition of the truck as well as the condition of the operating area.

Availability and specifications are determined regionally and are subject to change without notice. Please consult your authorised CESAB dealership for further details.
SPEC_R300_EN_2022 / Ucan V07 – Copyright CESAB Material Handling Europe.

